



***IWAKI AMERICA
RD SERIES
DIRECT DRIVE PUMP
INSTRUCTION MANUAL***

RD Series Direct Drive Pump
Table of Contents

1	Unpacking and Inspection	1
2	Operating Principle.....	1
3	Model Identification Guide	2
4	Specifications	2
5	Main Parts.....	3
6	Dimensions	4
7	Handling Instructions	5
8	Installation, Piping and Wiring	6
8.1	Installation	6
8.2	Piping Instructions	7
8.3	Wiring	8
9	Operation.....	10
▪	Notes on Operation	10
▪	Operation	10
▪	Pump Stopping Procedures	11
▪	How to store pump when it is out of use for a long time	11
▪	Draining Method.....	11
▪	Draining procedure.....	13
10	Troubleshooting and Maintenance	13
▪	Maintenance.....	14
11	Parts Description and Exploded View	14
▪	RD-05/05H	14
▪	RD-20/30.....	14

Thank you for selecting the RD Series Direct Drive Pump. This instruction manual explains the correct handling, operating, maintenance, inspection and troubleshooting procedures for your pump. Please read through it carefully to ensure the optimum performance, safety and long service of your pump.

1 Unpacking and Inspection

Open the package and check that the product conforms to your order. Also, check each of the following points. For any problem or inconsistency, contact your supplier at once.

1. Check that the model number, flow and head indicated on the nameplate conform to the specifications of your order.
2. Check that all the accessories you ordered are included.
3. Check that the pump body and parts have not been accidentally damaged or that any bolts or nuts have not been loosened in transit.

Iwaki Direct Drive Pump

MODEL			
MAX CAPACITY	l/min	VOLTS	V
MAX HEAD	m	AMPS	A
RATING			
DO NOT RUN PUMP DRY			
MFG No. _____			
IWAKI CO. LTD TOKYO, JAPAN			

2 Operating Principle

The RD Series pump is a canned motor type centrifugal pump driven by a DC brushless motor. The magnet incorporated with the impeller is directly rotated in the pump chamber by the magnetic force of the motor to discharge the liquid from suction port to the discharge port.

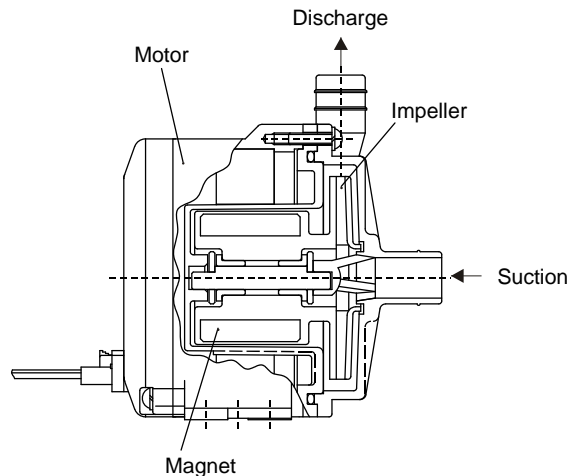

3 Model Identification Guide

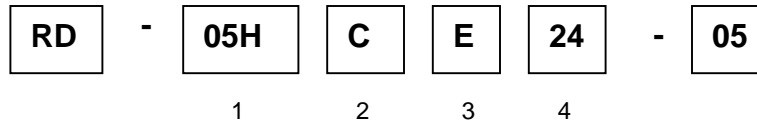

- 1 **Pump size** 05
 05H
 12
 12Z
 20
 30

- 2 **Bearing material**
 No symbol: PPS (with filler) for RD-05 & 05H
 PTFE for RD-20 & 30
 C: Carbon

- 3 **O ring material**
 V: FKM
 E: EPDM

- 4 **Power source voltage** 24: 24V
 12VDC option available for OEM applications, contact Iwaki America for details.

- 5 **Fluid Temperature Rating** No Symbol: 40 °C 05: 60°C

4 Specifications

Model	Bore (mm)		Max flow (L/min)	Max head (m)	Max Specific Gravity	Motor		Mass (kg)
	Suction	Discharge				Power (V)	Rated output (W)	
RD-05	14	8 4 3			1.0	DC24	3.5	0.4
RD-05H	14	8 6 9			1.0	DC24	17	0.5
RD-12	18/ 3/8 NPT	18/ 3/8 NPT	10	6	1.0	DC24	12	0.6
RD-12Z	18/ 3/8 NPT	10/ 1/4 NPT	3	9	1.0	DC24	14	0.6
RD-20 18		18	15	8	1.0	DC24	28	1.3
RD-30	18	18 20 10			1.0	DC24	45	1.3

Notes:

1. Performance data is based on pumping clear water at ambient temperature.
2. Max. flow based on discharge pressure of 0 psi and max. head based on operating pump at shut-off.
3. Max. allowable viscosity of liquid (at specific gravity 1.0): 1 cP (1mPa-s).

4. Ambient installed temperature range: 32 – 104 °F (0 - 40 °C).
5. Max. specific gravity is the value at maximum flow.
6. Motor specifications:

Pumps use a DC brushless motor equipped with the following protective functions in drive circuitry:

 - a. Protection against jammed impeller.
Drive circuitry will detect locked impeller and stop the pump.
 - b. Excessive temperatures.
The pump will stop when the motor temperature increases beyond rated temperature as a result of elevated fluid temperature or installed environment temperature.
 - c. Over current protection.
The drive circuitry is protected against excessive current (Note, RD-05 has no over current protection because of its low output).
 - d. Fuse
RD's are equipped with internal fuse to protect pump form overheating or causing damage to system when drive circuit has been damaged. The built-in fuse cannot be replaced, so, we recommend use of an external fuse.

Performance and dimensions of pumps may be changed without prior notice.

5 Main Parts

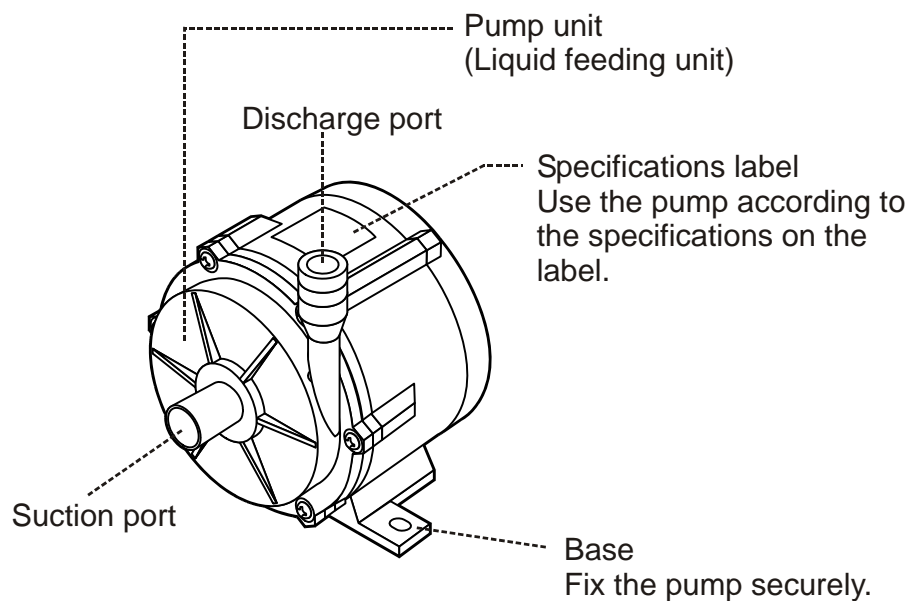

6 Dimensions

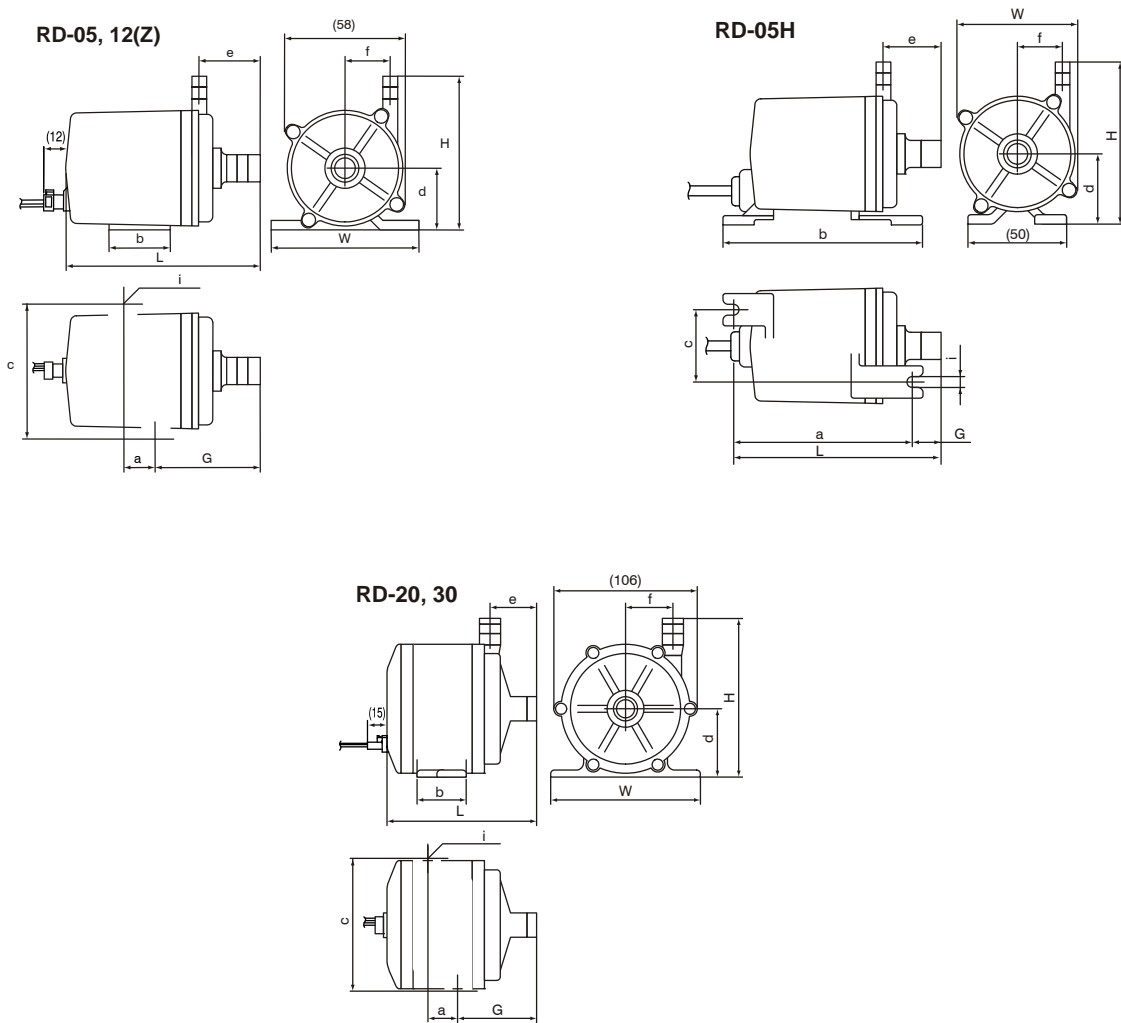

dimensions in inches (mm)

Model	W	H	L	a	b	c	d	e	f	G	i
RD-05	2.99 (76)	2.95 (75)	3.72 (94.5)	0.63 (16)	1.18 (30)	2.52 (64)	1.18 (30)	1.16 (29.5)	0.88 (22.4)	1.98 (50.5)	2- ϕ 5x7
RD-05H	2.28 (58)	3.07 (78)	4.25 (109.5)	3.54 (90)	3.94 (100)	1.38 (35)	1.30 (33)	1.16 (29.5)	0.88 (22.4)	0.57 (14.5)	2- ϕ 2x6
RD-12	3.07 (78)	3.21 (81.5)	3.68 (93.5)	0.63 (16)	1.18 (30)	2.60 (66)	1.20 (30.5)	1.24 (31.5)	0.71 (18)	2.05 (52)	2- ϕ 5x7
RD-12Z	3.07 (78)	3.13 (79.5)	3.68 (93.5)	0.63 (16)	1.18 (30)	2.60 (66)	1.20 (30.5)	1.24 (31.5)	0.78 (19.8)	2.05 (52)	2- ϕ 5x7
RD-20/30	4.41 (112)	4.69 (119)	4.33 (110)	0.87 (22)	1.46 (37)	3.82 (97)	1.93 (49)	1.38 (35)	1.42 (36)	2.34 (59.5)	2- ϕ 6x8

7 Handling Instructions



Warning

Switch off the power when the pump or its electrical parts get wet.
Keep the pump away from fire
Do not place dangerous or flammable substances near the pump.



Caution

Keep the impeller assembly away from any electronic device that could be affected by a strong magnetic field.
Do not run pump dry, this will result in excessive bearing wear and frictional heat damaging the pump.

1. Handle the pump carefully

Impacts caused by dropping the pump on the floor or striking it may result in damage or faulty performance.



2. Priming water

Be sure is installed with flooded suction and is full of liquid before operating.

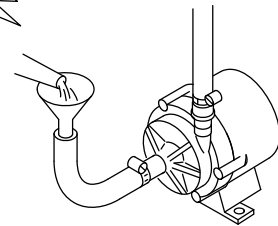

3. Magnet

There is a powerful magnet inside the pump liquid end, do not use any liquid that contains metallic substances such as iron, nickel, etc.

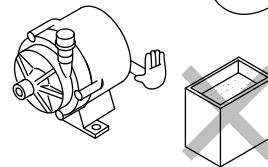

4. Do not install/operate the pump in the following places

- Places where the ambient temperature falls below 32°F (0°C).
- Places where corrosive gas (such as chlorine gas) is generated.
- Places exposed to splashing or dripping water.
- Places where the ambient temperature is 104 °F (40°C) or above.
- Places where explosive vapors or gases may be present.

The pump unit is not designed to be dust and waterproof.

5. Do not operate the pump with the following liquids

- Liquids that significantly are not compatible with materials of construction. Examples; Paraffinic hydrocarbons such as gasoline and kerosene. Halogenated hydrocarbons such as trichloroethylene and carbon tetrachloride.
- Slurry
(Never use pumps in slurry applications, as premature bearing wear will result in pump failure.)

For compatibility with chemical liquid or any special liquid, contact Iwaki America customer service.

6. If pump is damaged

Do not operate a damaged pump, electrical shock or a short circuit may occur.

7. Power cable

A broken or frayed power cable may cause an electrical shock. Do not bend, pull or twist power cords. Consult Iwaki America customer service if power cable is damaged and needs to be replaced.

8. Cleaning the pump

Do not clean the exterior of the pump with a solvent such as Benzene, alcohol, etc.

8 Installation, Piping and Wiring

8.1 Installation

▪ *Pump Location*

The pump must be installed in a location with an ambient temperature of 32 – 104°F (0-40°C) and a relative humidity lower than 85%. It is recommended the pump be installed so that it is easy to inspect and maintain..

▪ *Pump Position*

This pump is not the self-priming pump. The pump must be installed in a position lower than the liquid level of the supply tank. Recommended liquid level above pump suction is 12 inches (30 cm). This is to prevent the pump from sucking in air which will result premature or accelerated bearing wear.

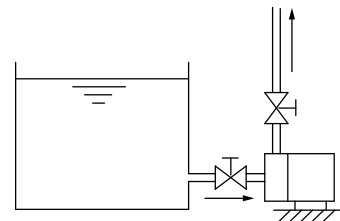

- **Pump basemounting**

The base of the pump must be anchored firmly to the mounting surface. It is recommended that the unit be installed in a horizontal position, however vertical mounting is acceptable provided adequate liquid level above inlet is present and air is properly vented.

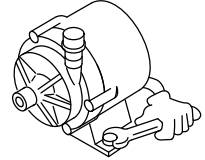

8.2 Piping Instructions

- The shortest pipe possible, with the minimum number of bends, should be designed. Arrange a proper support on the suction pipe so that the load and the thermal stress of the pipe itself are not applied to the pump.
- Use a corrosion-resistant vinyl hose that can endure the pressure created during pump operation. If the connection on the suction side is inadequate, air may be mixed in.
- **Hose size**
Select a hose in accordance with the diameter of the pump port. A reliable connection is not guaranteed if a different size hose is used.

As the hose on the suction side, in particular, tends to be crushed under the sucking force, the use of a braided hose is recommended. **(In case of hot liquid feeding, special attention must be paid in the selection of the hose.)**

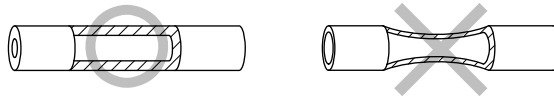

- **Valve installation**
Install valves close to the suction and discharge port.
Suction side:
For easy removal or maintenance of the pump.

Discharge side valve:
For adjustment of the discharge rate or head.

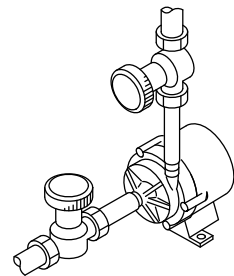

- **Hose connection**
Press the hose end firmly against the discharge or suction port until it reaches the bottom of the port.

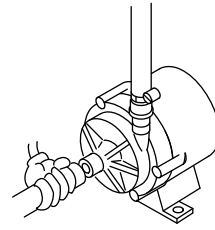

* Use a fastener (such as a hose band) to make the connection firm and free of liquid leakage.



Caution

Do not tighten the connection ports (suction and discharge) excessively as they are made of plastic resin and are easily damaged.

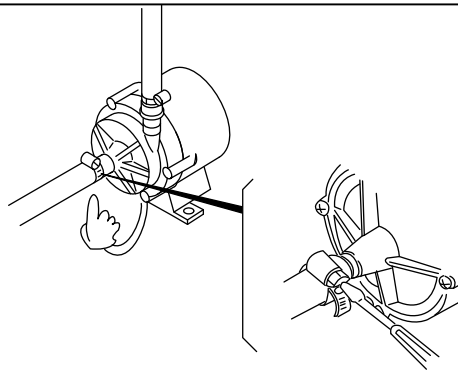

- Pay attention the load is not applied to inlet and outlet port.

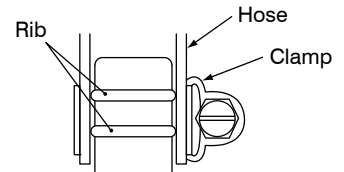

8.3 Wiring

Before you start wiring works, make sure the main power is switched off.

- Use appropriate wiring materials, follow the instruction manual for the motor and abide by the local and national electrical codes.
- Use specified voltage written on pump nameplate.
- Pump has no ON/OFF switch. Pumps start when power cable is connected. Do not frequent ON/OFF operation.
- In case external fuse is installed
When the fuse blows out, replace it and start pump after you settled the reason of blew out fuse. If the fuse blows out frequently, it may be caused by the starting current.

- Wires have polarity. Red is plus and black is minus. Wrong polarity will damage the motor. Motor does not rotate in reverse if the wires are connected in reverse.

Rated current, starting current

Model	Rated Current	Starting Current
RD-05V24 0.4A		1.5A
RD-05HV24 1.6A		4.0A
RD-12 1.0A		3.2A
RD-12Z 1.0A		5.0A
RD-20V24 2.5A		8.0A
RD-30V24 3.2A		10.0A

- If pump is switched ON and OFF, install the switch at the secondary side of DC power source (between power sources and pump). If power is ON and OFF at the primary side of DC power source, it is possible pump can not start.

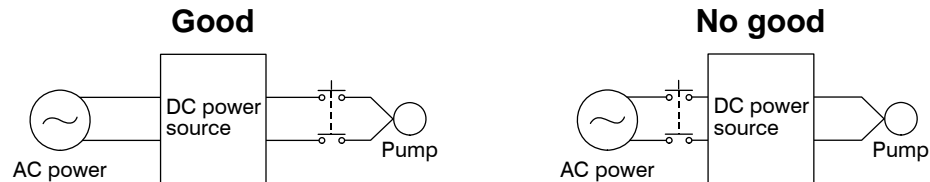

- Three (3) Wire Pumps

Red = 24 VDC

Black = GND * *Note*: Common for both the main power supply and speed control input

White = 0-5 VDC speed control

If two (2) power sources are not available, the white wire can be connected directly to 24 VDC to achieve full speed operation.

* *Note*: Must be less than 26.4 VDC or damage can occur

9 Operation

Notes on Operation



Caution

1. Before operating the pump, confirm that the pump is securely fixed and the hoses connected with the discharge port and suction port are firmly fixed in position.
2. Dry operation (operation without liquid in the pump) damages the pump. Be sure to fill the pump with priming liquid in advance.
3. Do not keep on operating the pump with entirely or almost closed discharge or/and suction side valve(s).
4. Do not open or close the suction or discharge side valve suddenly, otherwise the protective circuit operates, disabling the rotation of the impeller. (Under such circumstances, turn off the power supply.)
5. Frequent ON and OFF may cause the failure or damage of pump.
6. If foreign matters get into the pump, switch off power and remove them. Otherwise pump may be failed or damaged.

Operation

After the installation, piping and wiring processes are completed, operate the pump in accordance with the following steps.

No.	Operation Step	Description (Points to be checked)
1	Check piping, wiring and voltage	Check in accordance with the 'Hose connection' and 'Wiring' sections. Check the power supply voltage by referring to the information on the nameplate.
2	Open and close valves	Fully open suction side valve. Fully close discharge side valve.
3	Check that pump chamber is filled with liquid	Fill pump chamber with priming water (feeding liquid). Carry out sufficient priming in case of suction lift method.
4	Supply power to pump	After step 1 to 3 above, connect power supply to start pump. When pump is switched ON and OFF, take the interval of five or more seconds to switch ON again after switched OFF.

5	Adjust discharge capacity & head to desired ones	Adjust discharge side valves gradually till desired discharge capacity and head are obtained. <u>Do not open or close valves suddenly.</u> <i>Note: Do not keep discharge side valve closed for more than 1 minute for flow rate of 0.1L/min. or less</i> <i>Note: Check that pump feeds liquid normally. If not, turn off power immediately and eliminate cause referring to 'Causes of Trouble and Troubleshooting' section.</i>
6	Checkpoints during operation	Be careful to prevent foreign matters from entering the pump. Foreign matters in pump may cause impeller to be locked, hindering liquid circulation. Motor itself continues to rotate even if impeller is locked. In such a case, turn off power supply at once.

- **Pump Stopping Procedures**

No.	Stopping Step	Description
1	Close discharge side valve	Close discharge side valve gradually. Do not use electromagnetic valve for quick closing.
2	Turn off power supply. (Check stopping condition.)	Check that motor stops smoothly after power is disconnected. If not, pump should be inspected. (For details, contact Iwaki or your dealer.)

- **How to store pump when it is out of use for a long time**

Remove the liquid from the pump when it is stored for a long time. In addition, run it with water circulating for about 5 minutes every 3 months to prevent rust on the motor bearing.

- **Draining Method**



Warning

1. Before starting the draining procedure, turn off the power supply.
2. Be sure to wear proper safety gear (gloves, protective shoes, etc.) during draining work. When chemical liquid is used, wear rubber gloves, goggles).



Caution

3. Pay special attention to the remaining liquid which may run out of the discharge port or the suction port when removing the hose. Pay attention not to allow the motor or electric parts to come into contact with the liquid.
4. Never discharge hazardous or chemical liquid over the ground or floor in the plant. Instead, use a draining pan (or container). Observe each applicable local law or regulation for the handling or disposal of hazardous liquids.
5. Motor is not dust and waterproof construction. Do not wet pump.

▪ **Draining procedure**

1. Turn off the power supply. (Make sure no other operator will turn on the power supply accidentally.)
2. Fully close the discharge and suction sides valves.
3. Remove the hoses connected with the discharge and suction ports.

Position the draining pan below the pump unit in advance. Loosen the hose band and rotate the hose clockwise and counterclockwise slowly to completely pull the hose off of each port. (Liquid will run out when the hose is disconnected.)

4. Remove the screws on the pump base to detach the pump unit.
5. Direct the discharge port downward to drain the liquid into the draining pan.

Never discharge hazardous liquid, over the ground or the floor inside the plant. Use a draining pan (or container).

10 Troubleshooting and Maintenance

Cause	Excessive heat	Pump does not start	Insufficient pumping	Electric current is too high	Excessive noise or vibration	Liquid leaks	Troubleshooting
Power is not supplied or wiring is faulty		○		○			Check and correct wiring
Motor is out of order (disconnect coil or capacitor failure)	○	○		○	○		Contact your dealer
Air in pump			○		○		Eliminate air completely
Air is sucked in via suction port			○				Fasten hose tightly
Pump runs dry			○	○	○	Check	pipng
Specific gravity/viscosity of liquid is too high	○		○	○			Use suitable type of pump
Impeller magnet touches rear casing			○	○	○		Contact your dealer
Impeller is damaged			○	○	○		Contact your dealer
Foreign matter adheres to impeller			○	○	○		Contact your dealer
O ring is damaged						○	Contact your dealer
Loosened front casing fixing bolts			○			○	Tighten bolts
Too high liquid & ambient temperature	○						Contact your dealer
Lack of power volume		○					Check power volume

- **Maintenance**

1. **Tighten bolts**

While the pump is running for a long time, it may happen the bolts are loosened. In this case tighten the bolts. Also tighten the bolts after the pump are stocked for a long period.

2. **Daily Inspection**

Check to see the operating condition of the pump such as vibration, sound, electric current and flow rate and as soon as you find any abnormality, switch off the power and settle the abnormality referring to the item “Troubleshooting”.

3. **Spare Parts (Consumable parts)**

When the pump is continuously used for a long period, we recommend you to stock consumable parts such as impeller and O ring.

11 Parts Description and Exploded View

- **RD-05/05H/12(Z)**

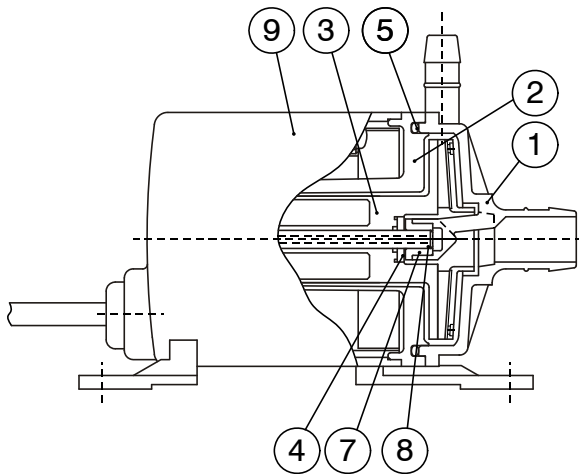

No.	Parts Name	Qty	Material
1	Front casing	1	PPE
2	Rear casing	1	PPE
3	Impeller	1	GFRPP
4	Thrust	2	Ceramic
5	O-ring	1	FKM or EPDM
7	Bearing	2	PPS or Carbon
8	Spindle	1	Ceramic
9	Motor	1	

- **RD-20/30**

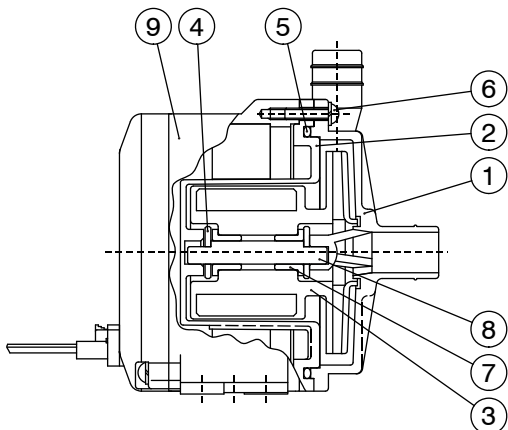

No.	Parts Name	Qty	Material
1	Front casing	1	PPE
2	Rear casing	1	PPE
3	Impeller	1	GFRPP
4	Thrust	2	Ceramic
5	O-ring	1	FKM or EPDM
6	Pan head screw (with SW, PW)	6 SS	
7	Bearing	2	PPS or Carbon
8	Spindle	1	Ceramic
9	Motor	1	