

Model	MX-F400			
Mark	CFV	RFV	KKV	AFV
1 Front casing	CFRETFE			
2 Impeller	CFRETFE			
3 Rear casing	CFRETFE			
4 Magnet capsule	CFRETFE			
5 O-ring*	FKM*			
6 Spindle	High purity Alumina Ceramic		SiC	High purity Alumina
7 Bearing	Carbon	PTFE	SiC	High purity Alumina
8 Rear thrust	CFRETFE			
9 Mouth ring	PTFE		SiC	PTFE
10 Thrust/Liner ring	High purity Alumina Ceramic		SiC	High purity Alumina

* EPDM and AFLAS® O-ring also available.

MX-F400 .75

- Engineered to meet the most severe operating conditions.
- When fitted with a carbon bearing, the MX will allow for brief periods of dry running.
- Self-radiating structure (patent pending) – Heat dispersion holes force the liquid to circulate around the spindle and bearing .

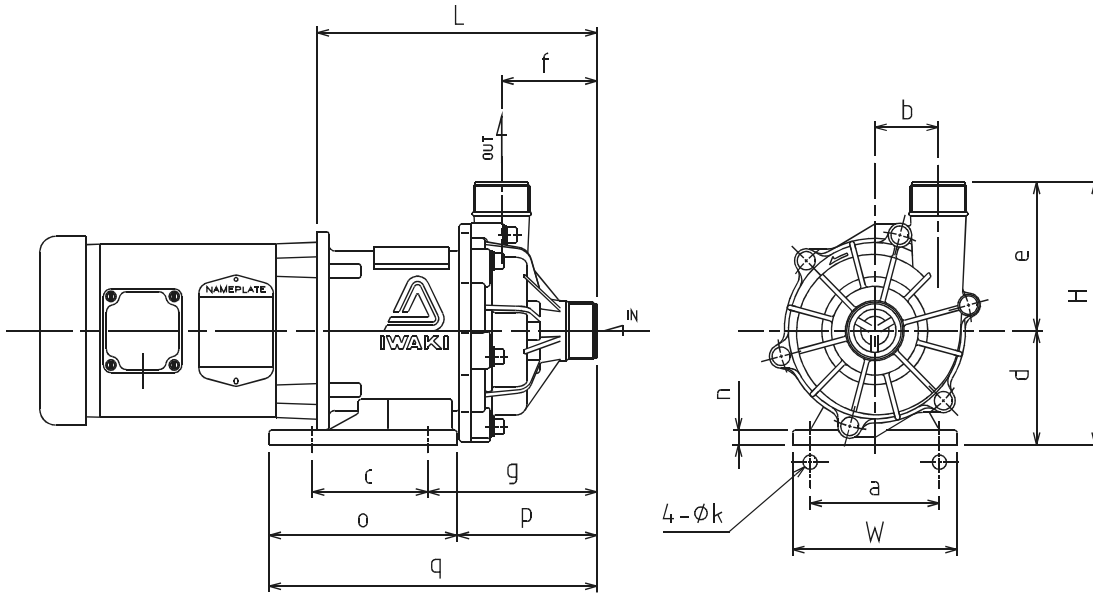

Dimensions (in inches)

a	b	c	d	e	f	g	k	n	o	p	q	W	H	L
4.33	2.13	3.86	3.74	4.88	3.19	5.67	.47	.47	6.30	4.69	10.98	5.51	8.62	9.37

Specifications

Suction x Discharge	Maximum Discharge Pressure	Maximum Flow	Specific Gravity	Weight (less motor)
1.5" x 1.5"	V = 43 ft. X = 34 ft.	65 gpm	1.2	13.7 lbs

