

1 2 3 4 5 6 7 8 9 10 11 12 13 14 15 16 17 18 19 20 21 22 23 24 25

PART OR DRAWING NO.
IF20597

REV.
A

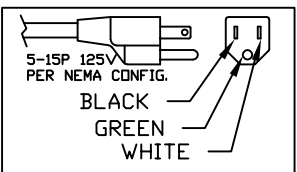
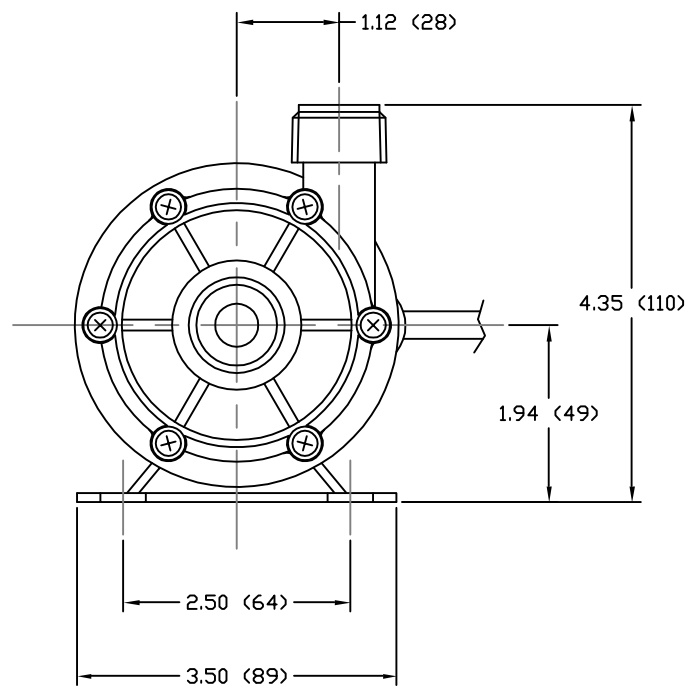
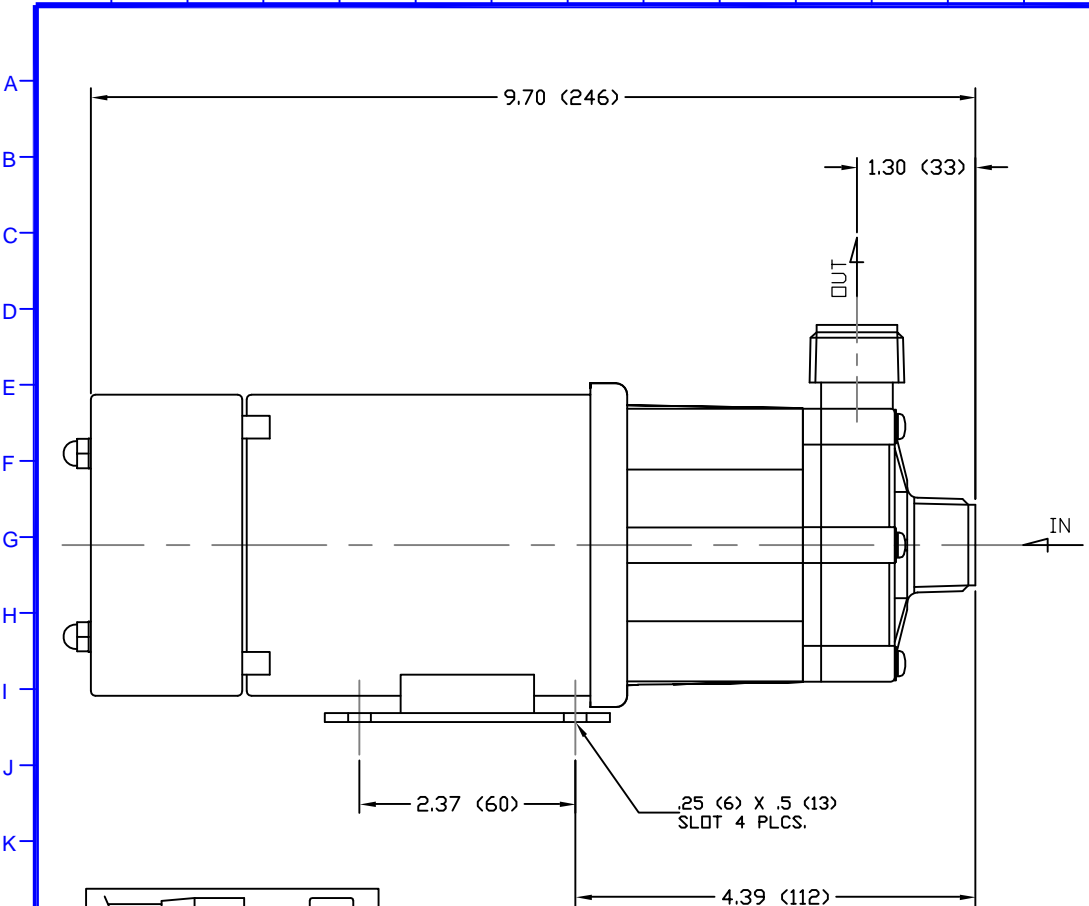

- NOTES:
1. DRAWING MAY VARY FROM ACTUAL PRODUCT
 2. DRAWN TO SCALE PER 2Z000403.
 3. REFER TO DRAWING 54206 & 54218.
 4. DIMENSIONS ARE IN INCHES (MM).

MATERIALS	
CASING	GFRPP
IMPELLER	GFRPP
SPINDLE	ALUMINA CERAMIC
BEARING	PTFE
THRUST RING	ALUMINA CERAMIC
O-RING	FKM

SPECIFICATIONS	
MAX CAPACITY	8.2 GPM (31 LPM)
MAX HEAD	14.1 FT (4.3 M)
MAWP	9.95 PSI (.07 MPA)
VOLTAGE	115 VAC
CURRENT	.48 A
CORD LENGTH	72 IN ± 2 IN (1.83 M ± .05 M)
WEIGHT	7 LBS (3.2 KG)
SUCTION	3/4 IN NPT - MALE
DISCHARGE	3/4 IN NPT - MALE

ECO#	DESCRIPTION				DATE	REV. LTR.	
MATERIAL SEE CHART							
GJS	06	04	05	XXX	1	PART OR DWG. NO. IF20597	
DRAWN	DAY	MO.	YR.	RELEASED	SHEET NO.		
		5 Boynton Rd. Hopping Brook Park Holliston, MA 01746 (508) 429-1440					REV. A
		www.IwakiAmerica.com					
TITLE MAG DRIVE PUMP WMD-20RLT (115V)							