

1 2 3 4 5 6 7 8 9 10 11 12 13 14 15 16 17 18 19 20 21 22 23 24 25

PART OR DRAWING NO. IF20568 REV. A

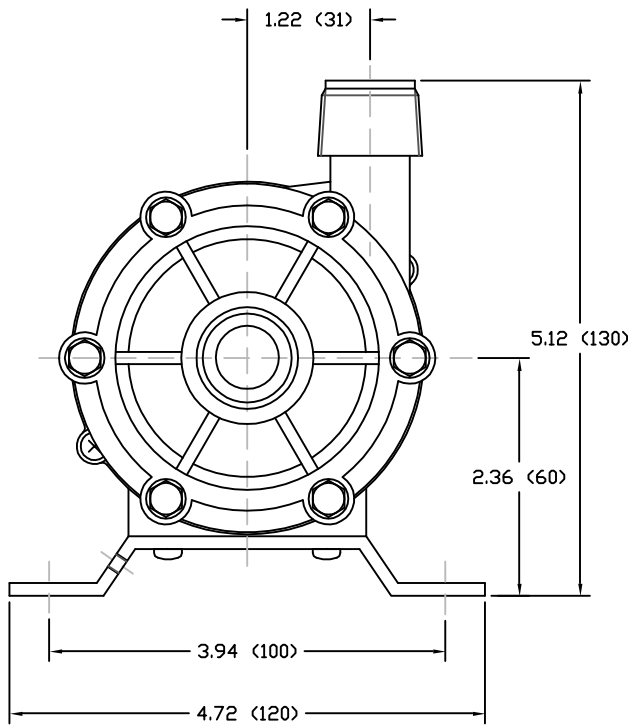
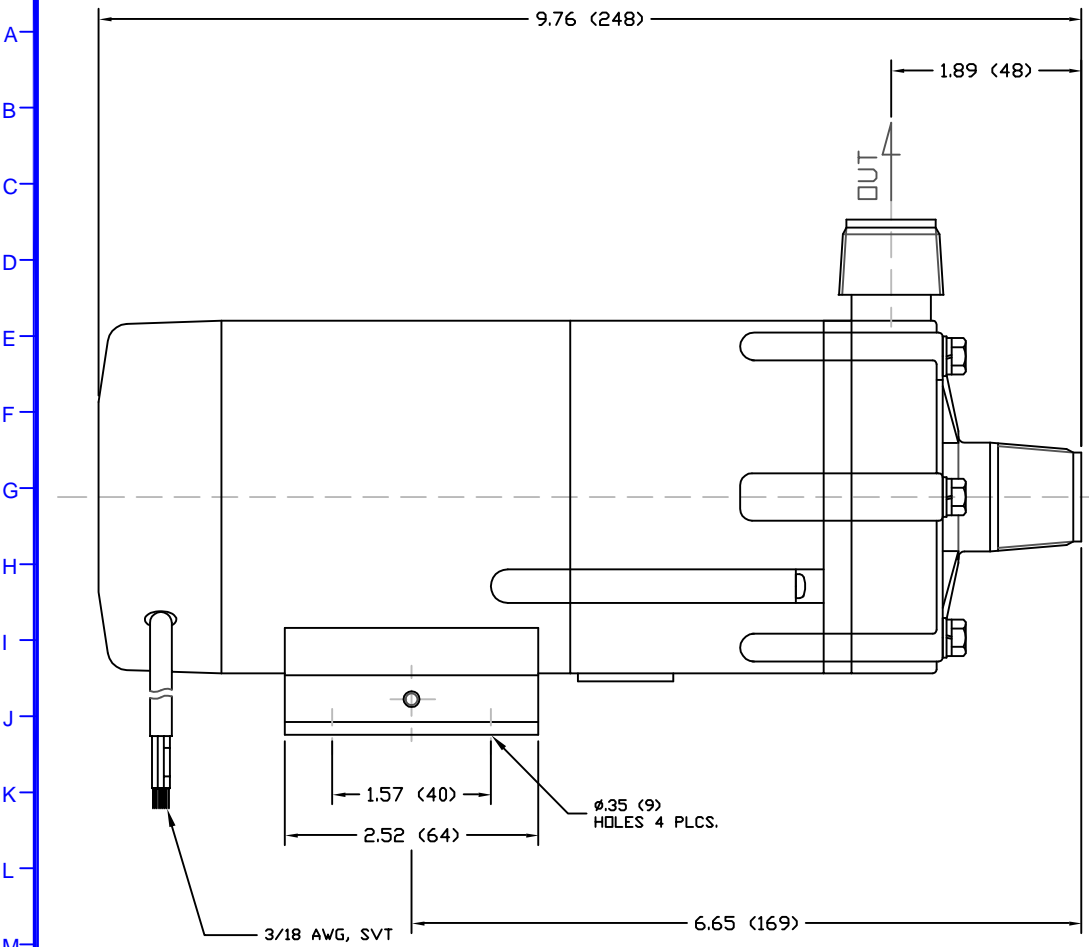

- NOTES:  
 1. DRAWING MAY VARY FROM ACTUAL PRODUCT  
 2. DRAWN FROM 22000409 TO SCALE.  
 3. REFER TO SPECIFICATION C910710.  
 4. DIMENSIONS ARE IN INCHES (MM).

SPECIFICATIONS	
MAX CAPACITY	10 GPM (37.9 LPM)
MAX HEAD	17.7 FT (5.39 M)
MAWP	11.6 PSI (.08 MPA)
VOLTAGE	115 VAC
CURRENT	0.8 A
CORD LENGTH	39.4 IN (1 M)
WEIGHT	7.7 LBS (3.49 KG)
SUCTION	3/4 IN NPT - MALE
DISCHARGE	3/4 IN NPT - MALE

MATERIALS

CASING	GFRPP
IMPELLER	GFRPP
SPINDLE	ALUMINA CERAMIC
BEARING	PTFE
THRUST RING	ALUMINA CERAMIC
O-RING	FKM

ECO#	DESCRIPTION	DATE	REV. LTR.
MATERIAL SEE CHART			
GJS	04 03 05	XXX	1
DRAWN	DAY	MO.	YR.
		RELEASED	SHEET NO.
 <a href="http://www.IwakiAmerica.com">www.IwakiAmerica.com</a>		5 Boynton Rd. Hopping Brook Park Holliston, MA 01746 (508) 429-1440	
		TITLE MAG DRIVE PUMP MD-30RT (115V)	

PART OR DWG. NO. IF20568 REV. A