

(W)MD-100F

- Twin bearing system handles thrust loads, extends service life
- Hollow rotating / Internal cooling circuit reduces bearing temperature
- Compact / Quiet energy efficient design
- Few moving parts for easy maintenance

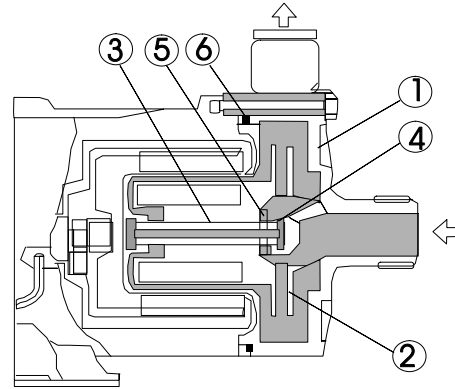
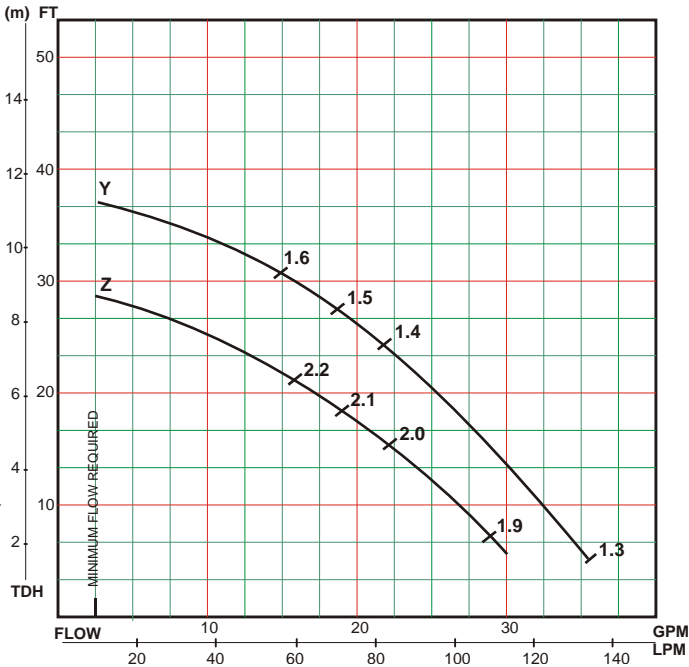

Part	Material
1 Casing	CRFETFE
2 Impeller	
3 Spindle	SiC
4 Bearing	SiC
5 Thrust Ring	SiC
6 O-ring	FKM

Dimensions in inches (mm)

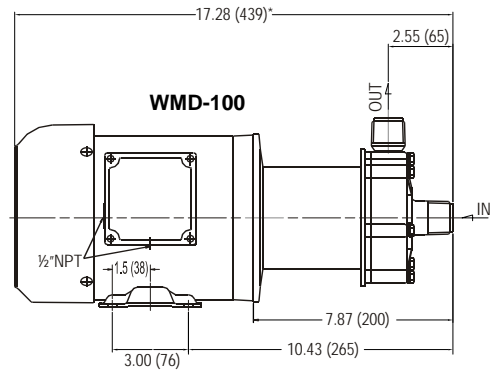
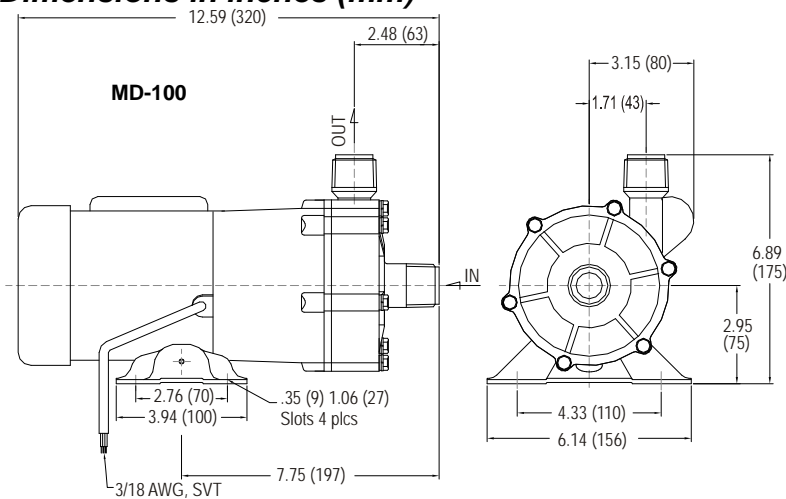

* For reference only

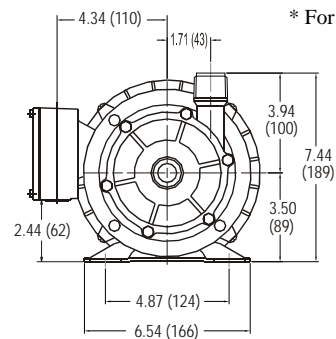

Specifications

* Varies with motor manufacturer

Model	CONNECTIONS		MOTOR		AMPS 115V	MAX FLOW GPM	MAX HEAD FT	MAX SYS PRESSURE PSI	S.G.	WEIGHT LBS
	HOSE	NPTM	OUTPUT (HP)	SPEED (RPM)						
MD-100FY	----	1	1/3	3300	3.4	35.7	37.7	31.2	1.3 (1.6)	18.7
WMD-100FY	----	1	1/3	3450	*	36.0	38.0	31.2	1.3 (1.6)	*
MD-100FZ	----	1	1/3	3300	3.4	30.4	27.8	31.2	1.9 (2.2)	18.7
WMD-100FZ	----	1	1/3	3450	*	28.0	27.2	31.2	1.9 (2.2)	*