

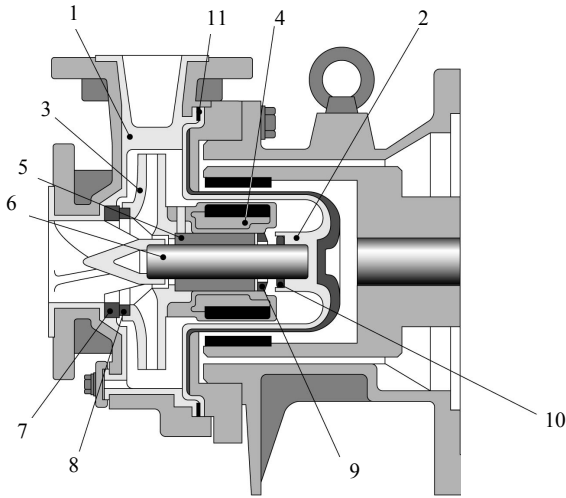

MDM-2526 7.5/10HP



- ❑ Non-contact Bearing System allows dry run operation (CF models only)
- ❑ Simple, rugged design
- ❑ Corrosion resistant ETFE & PFA internals
- ❑ Spline/pinned impeller design (pat. pending) provides positive locking of impeller/inner magnet while still allowing for individual replacement of each part

Part	Material		
	ECF	EKK	PKK
1 Front casing	CFRETFE		PFA
2 Containment shell	(carbon fiber reinforced ETFE)		
3 Impeller			
4 Inner magnet assy			
5 Bearing	High density carbon	SiC	
6 Shaft	High purity alumina ceramic		
7 Front outboard thrust collar			
8 Front inboard thrust collar	PTFE		
9 Rear inboard thrust collar	High purity alumina ceramic		
10 Rear outboard thrust collar	PTFE (filler charged)	PTFE	
11 Gasket	PTFE		

Dimensions (inches) and Specifications

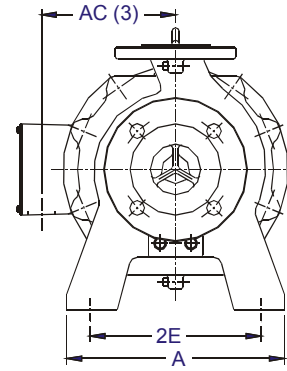
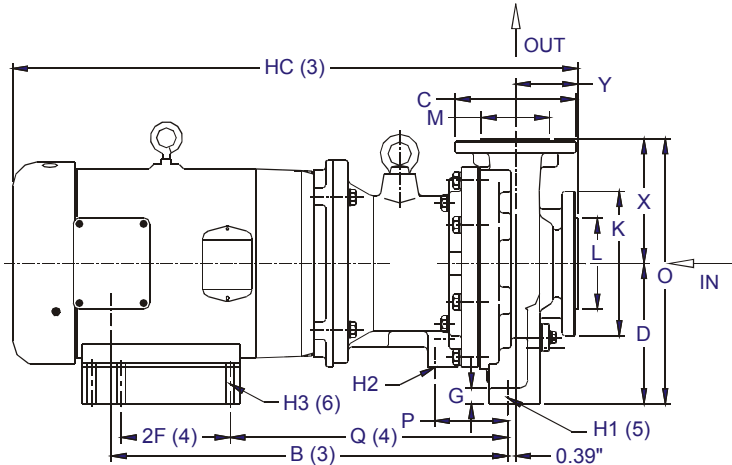
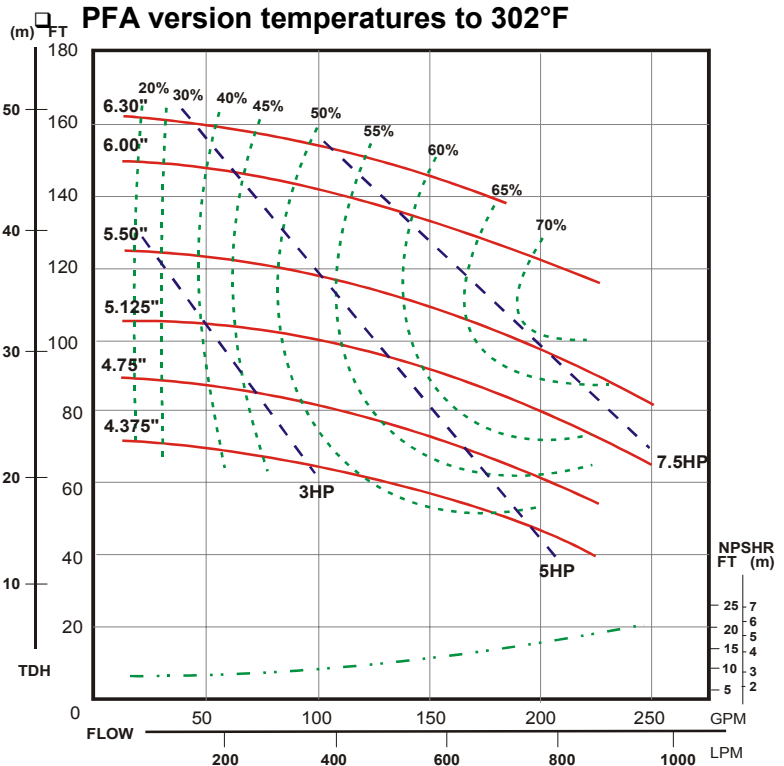

Note: Will vary by motor manufacture * Pump end only. Does not include motor.

A	AC(3)	B(3)	D	2E1	2F(4)	G	H1(5)	H2	H3(4)	HC(3)	O	P	Q(4)	X	Y
11.02	6.79	20.07	7.09	8.66	5.50/7.00	0.79	0.55	3/8-16UNC	0.41	28.62	13.39	3.70	14.07	6.30	3.15
HP/Frame		Connection Sizes		Min Flow/Max Head		Standard Capacity		Max Capacity		Pump Weight*		K	L	C	M
7.5/213TC & 10/215TC		2.5 x 2		13/162		180		260		132		7.28	4.61	6.10	3.46

IF20431.F 1/05

5 BOYNTON ROAD HOPPING BROOK PARK HOLLISTON, MA 01746-1446 USA
 TEL: 508-429-1440 FAX: 508-429-1386 WEBSITE: WWW.IWAKIAMERICA.COM