

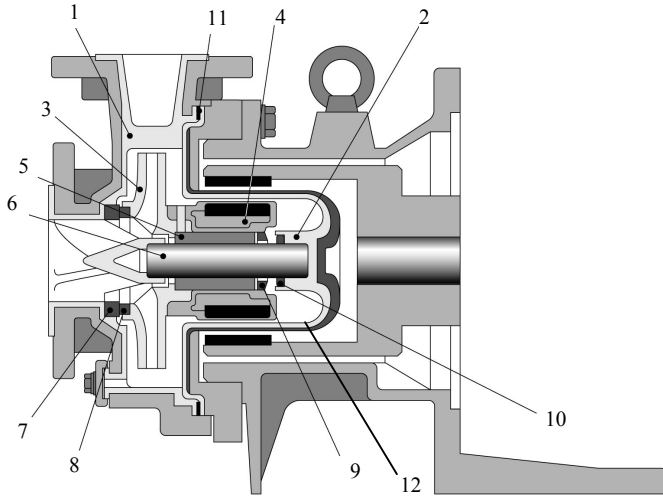

MDM-2158 25HP



- ❑ Exceeds ANSI Performance standards
- ❑ Simple, rugged, modular design
- ❑ Dual back pull-out
- ❑ Non-contact Bearing System allows dry run operation (CF models only)

Part	Material		
	ECF	EKK	PKK
1 Front casing	CFRETFE (carbon fiber reinforced ETFE)		PFA
2 Containment shell			
3 Impeller			
4 Inner magnet assy			
5 Bearing	High density carbon	SiC	
6 Shaft	High purity alumina ceramic		
7 Front outboard thrust collar	PTFE		
8 Front inboard thrust collar			
9 Rear inboard thrust collar	High purity alumina ceramic		
10 Rear outboard thrust collar	PTFE (filler charged)		PTFE
11 Gasket	PTFE		
12 Support	Kevlar®		

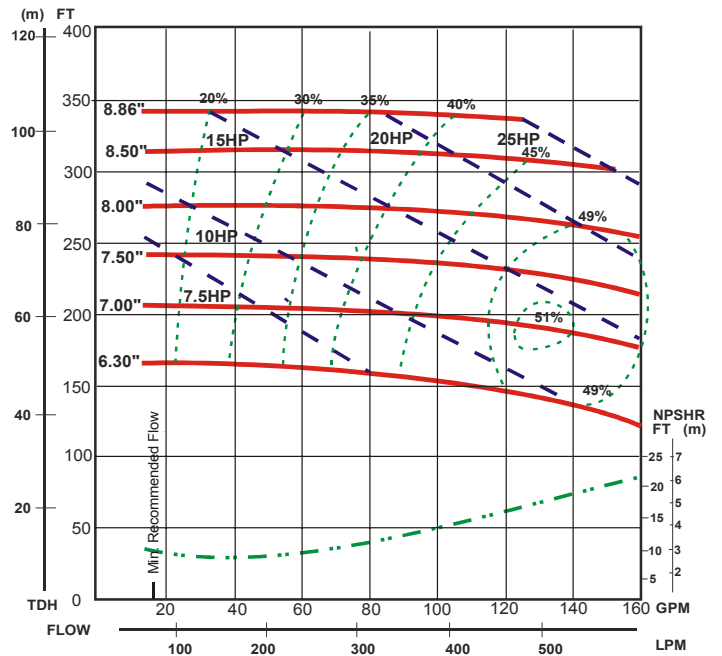

Dimensions (inches) and Specifications

Note: Will vary by motor manufacturer

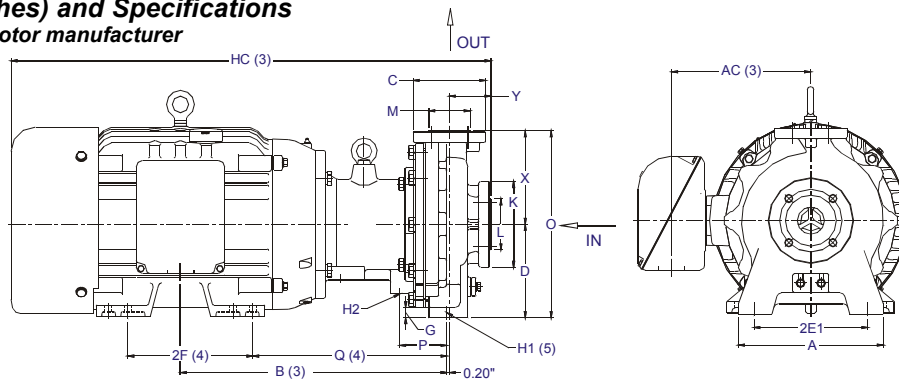

*Pump end only. Does not include motor.

A	AC(3)	B(3)	D	2E1	2F(4)	G	H1(5)	H2	H3(4)	HC(3)	O	P	Q(4)	X	Y	
11.02	10.56	20.27	7.00	8.66	9.50/11.00	0.70	0.55	3/8-16UNC	0.52	36.50	14.09	3.58	14.77	7.09	3.15	
HP/Frame			Connection Sizes		Min Flow/Max Head		Standard Capacity		Max Capacity		Pump Weight*		K	L	C	M
25/284TSC			2 x 1.5		13/343		125		160		165		6.50	3.86	5.51	3.15