

1 2 3 4 5 6 7 8 9 10 11 12 13 14 15 16 17 18 19 20 21 22 23 24 25

PART OR DRAWING NO. **IF20419** REV. **C**

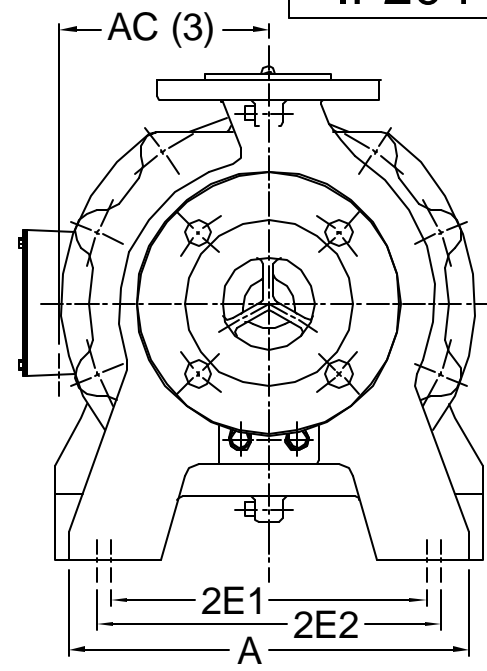
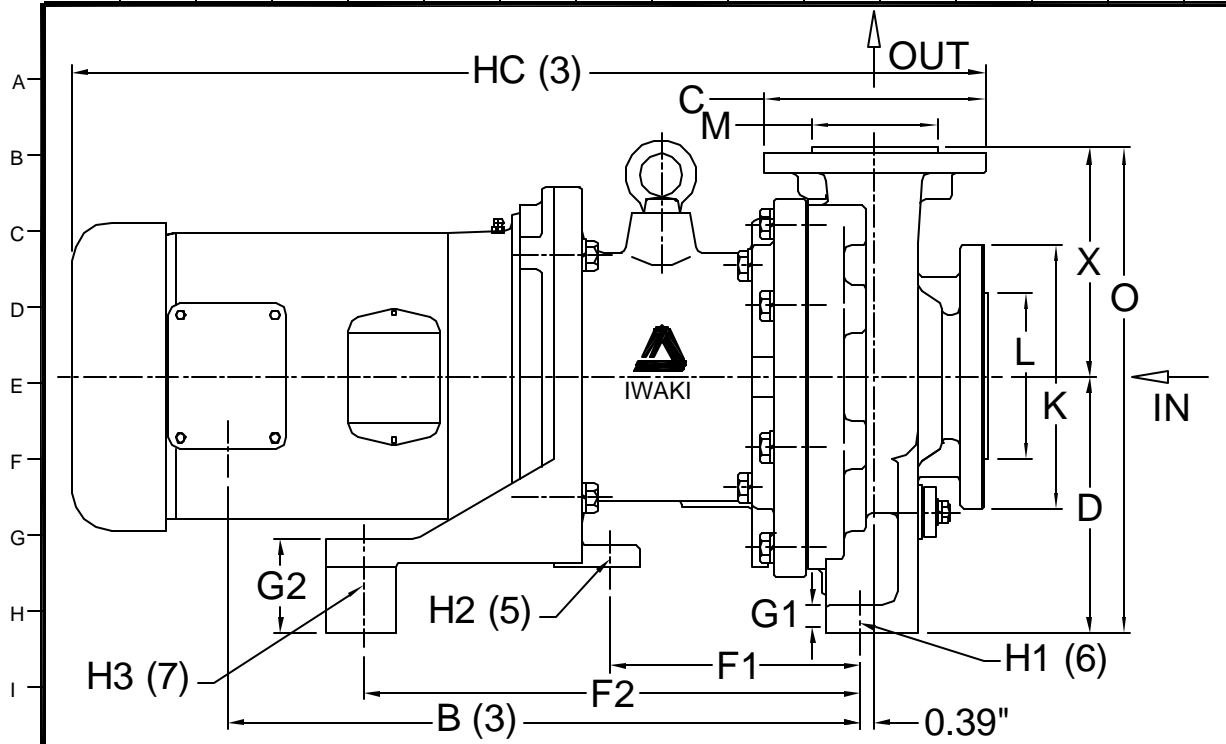

**PUMP DIMENSIONS (1)**

A	AC (3)	B (3)	D	2E1	2E2	F1	F2	G1	G2	H1(6)	H2 (5)	H3	HC (3)	O	X	Y
11.02"	5.76"	17.41"	7.09"	8.66"	9.45"	6.89"	13.68"	0.60"	2.62"	0.55"	0.63"	0.63"	25.13"	13.39"	6.50"	4.00"

MODEL	HP/ FRAME	PUMP FLANGES (2)		DIMENSIONS			
		SUCTION	DISCHARGE	K	L	C	M
<b>MDM-2156</b>	5/184TC	2"	1.5"	6.50"	3.78"	5.51"	3.07"
<b>MDM-2526</b>		2.5"	2"	7.28"	4.61"	6.10"	3.47"

**NOTES AND REFERENCES:**

- (1) ALL DIMENSIONS IN INCHES. ALL TOLERANCES  $\pm .125"$ , CONSULT IWAKI AMERICA FOR MORE DETAILS. ACTUAL PRODUCT MAY DIFFER ON SOME POINTS.
- (2) BOLT HOLE LOCATIONS OF SUCTION AND DISCHARGE FLANGES CONFORM TO ANSI B16.5 150 LB STANDARD.
- (3) DIMENSION MAY VARY BASED ON MOTOR SIZE AND MANUFACTURER.
- 4 NEMA MG 1-1993, PART 4 USED FOR REFERENCE.
- (5) SLOT IS OPEN ENDED TO FRONT OF FRAME.
- (6) SLOTS ARE OPEN ENDED TO REAR OF FRAME.
- (7) SPACER MDM8001, 1.83" HEIGHT WITH THROUGH HOLE.
- 8 DRAWN PER 2A401437 (MDM F05A- 2).

10619 NEW FORMAT AND NOTES EDT 08-01-04

ECO#	DESCRIPTION	DATE	REV. LTR.
WEIGHT	132 LB	WET-END MATERIALS	CFRETTE OR PFA
EDT	03 08 04	CJC	1
DRAWN	DAY MO. YR.	RELEASED	SHEET NO.



5 Boynton Rd.  
Hopping Brook Park  
Holliston, MA 01746  
(508) 429-1440  
www.IwakiAmerica.com

TITLE **MDM-2XX6 (5 HP)**  
Dimensional Drawing

PART OR DWG. NO. **IF20419** REV. **C**