

Standard Product Capabilities

Pump solutions from a World Leader



MDM Series

Dry run capable chemical process pump

MDM is a wide ranging line of chemical process pumps designed to solve the most demanding chemical handling applications. Two materials of construction and convenient mounting configurations allow MDM to handle many aggressive chemical and high purity applications.

Unexpected dry running won't damage the pump or interrupt the process. Our new design allows the pump to handle these situations with ease.

High purity process fluid will not be contaminated by trace metals due to our combination of high purity materials and meticulous construction.

High strength rare earth magnets are totally encapsulated within fluororesin moldings. Small, lightweight and perfectly concentric magnet capsules optimize pump efficiency.

Installation and maintenance time are reduced with our compact, close-coupled design. Operating costs are reduced thanks to simple, modular construction and individually replaceable parts.

An expanded temperature range (up to 300°F) as well as increased solids handling capabilities (up to 10%) provides users with solutions for their difficult applications.

MDM pumps feature enhanced slurry capability when fitted with a new specially designed bearing system.

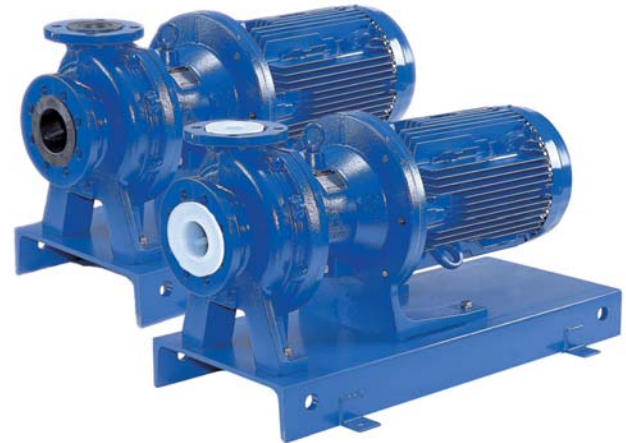

**DRY RUN CAPABLE FOR
HANDLING TOUGH CHEMICALS**

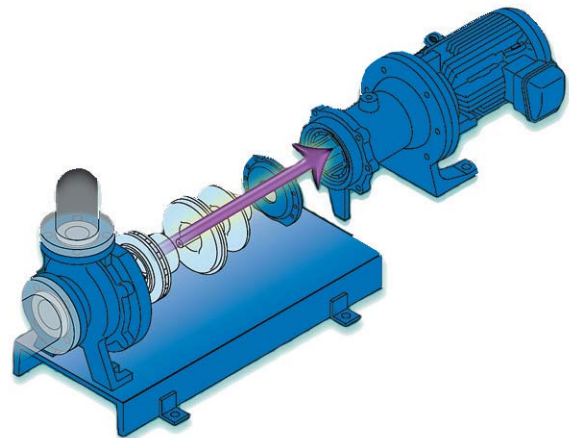

MDM's back pullout design allows the operator to inspect the pump while leaving the line pressurized. The pump features safety measures that prevent liquid from leaking when the foot support is pulled back. MDM's modular design keeps your operating cost low over the life of the pump by making regular maintenance and periodic inspection a snap.

Think twice. Spec Once.





MODEL CODE

MDM - 1518 EKK 05 H S
 A B C D E

A Pump Size

Model	Suction	Discharge	Motor HP
1516	1½	1	2/3
1518	1½	1	5 / 7.5 / 10
1518-2	1½	1	7.5/10/15/20/25
2156	2	1½	5 / 7.5 / 10
2158	2	1½	7.5/10/15/20/25
2526	2½	2	5 / 7.5 / 10
326	3	2	7.5 / 10 / 15 / 20 / 25

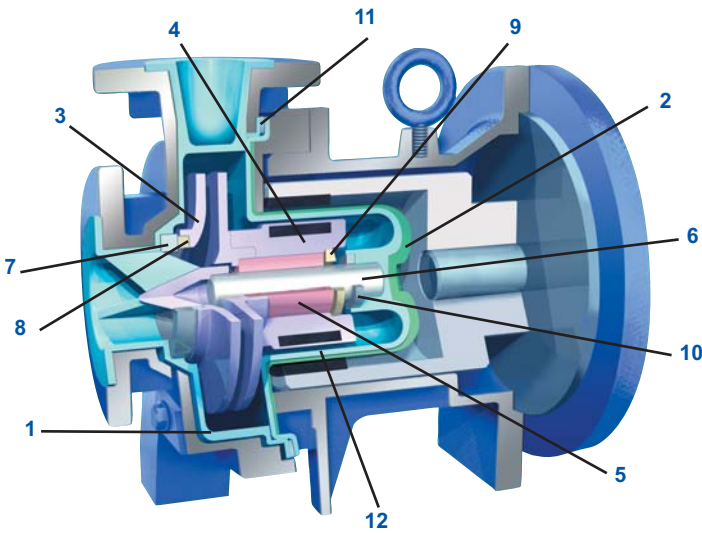

B Liquid End Construction

Materials	ECF	EKK	PKK
1. Front casing	CFRETFE		100% PFA
2. Rear casing			
3. Impeller			
4. Inner magnet			
5. Bearing	High density Carbon	SiC	SiC
6. Shaft	High purity Alumina Ceramic		
7. Outboard forward thrust collar			
8. Inboard front thrust collar			
9. Inboard rear thrust collar	High purity Alumina Ceramic		
10. Outboard rear thrust collar	PTFE (with filler)		PTFE
11. Gasket	PTFE		
12. Support	For High temperature versions (1518-2 and 2158) only used on fluids 176°F (80°C) and above		

C Motor Size

'C' in model code	HP	Frame Size
02	2 HP	145TC
03	3 HP	182TC
05	5 HP	184TC
07	7 HP	213TC
10	10 HP	215TC
15	15 HP	254TC
20	20 HP	256TC
25	25 HP	284TSC

D H = High Temperature Version
 (1518-2 and 2158 only)

E S = Slurry Bearing Design



PERFORMANCE CURVES

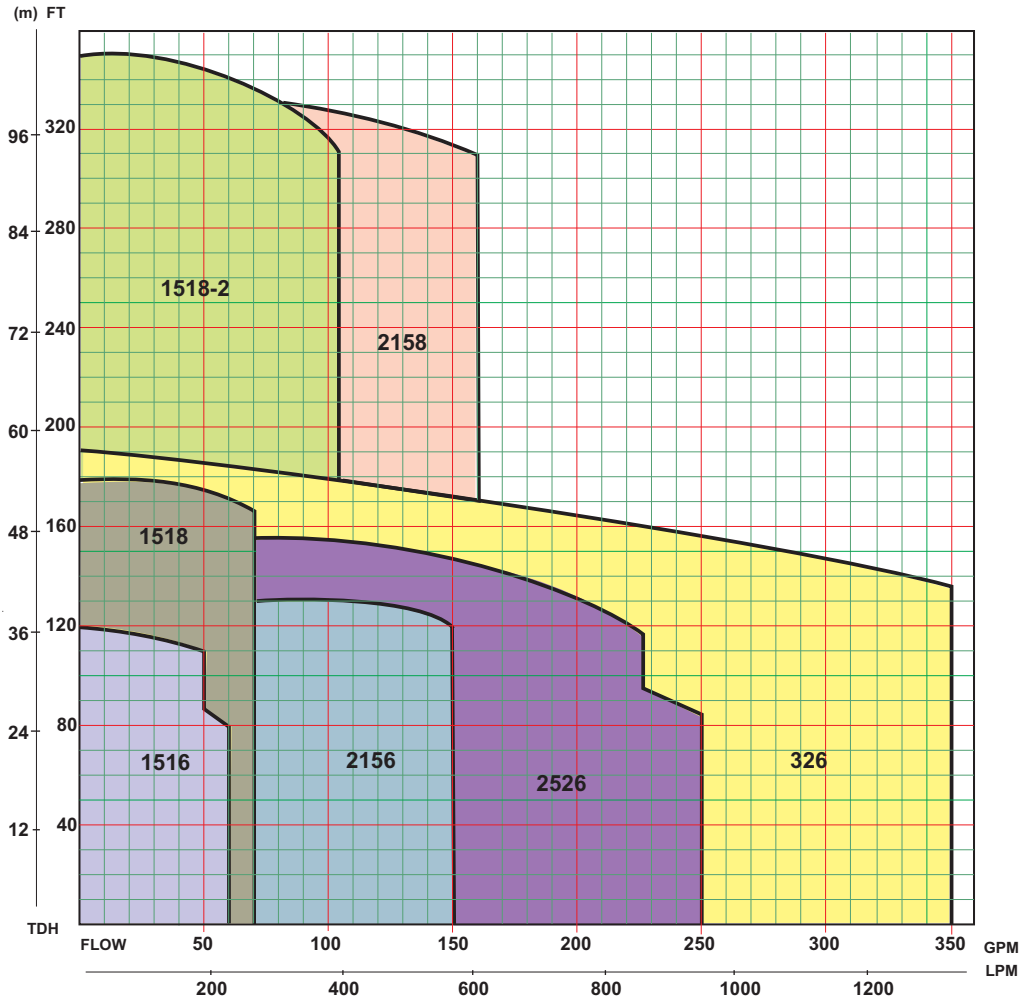

SPECIFICATIONS

Model	Connections Suct x Disch 150# (inch)	Nominal Impeller Dia. (inch)	BEP Capacity @60Hz (GPM)	BEP Head (ft)	Min Flow Rate (GPM)	Nominal Motor (RPM)	Motor (HP)
1516*	1½ x 1	5.52	50	108	5	3500	2,3
1518*	1½ x 1	6.7	70	167	5	3500	5, 7.5, 10
1518-2*	1½ x 1	8.86	120	310	13	3500	7.5, 10, 15, 20, 25
2156	2 x 1½	5.71	150	116	13	3500	5, 7.5, 10
2158	2 x 1½	8.86	130	190	13	3500	7.5, 10, 15, 20, 25
2526	2½ x 2	6.3	225	118	13	3500	5, 7.5, 10
326*	3 x 2	6.7	275	150	13	3500	7.5, 10, 15, 20, 25

* ANSI dimensional pump

LIQUID TEMPERATURE RANGE

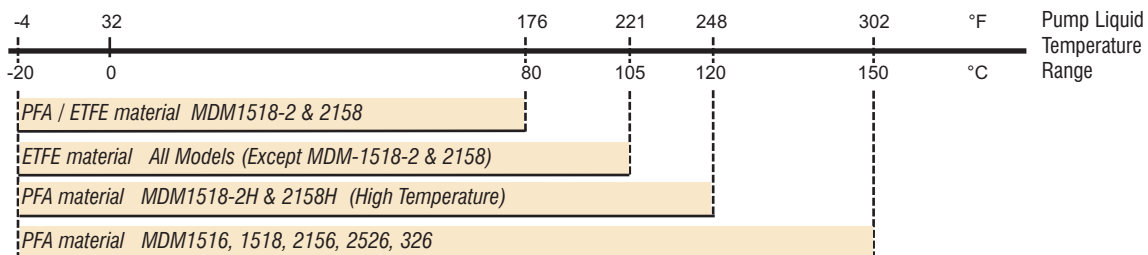

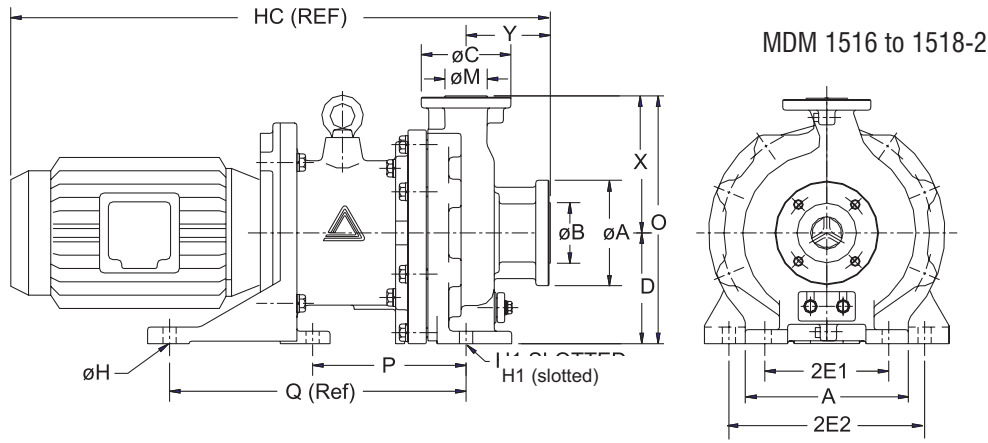

MDM 1518 to 326, 7.5-25 HP

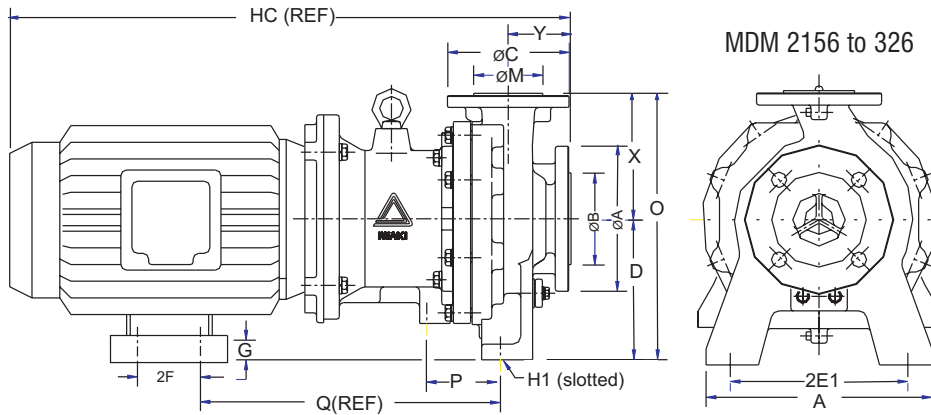

Dimensions
inches (mm)

MDM Model	Frame	HC	D	2E1	2E2	A	Q	P	G	H	H1	O	X	Y	Weight w/o Motor
1516*	145TC	20.58 (522.7)	5.25 (133.3)	5.98 (151.9)	9.45 (240.3)	11.42 (290)	9.25 (234.9)	7.25 (184.2)	---	0.63 (16)	0.63 (16)	11.76 (298.7)	6.5 (165.1)	4.0 (101.6)	100 lbs
	182TC	29 (736.6)	5.25 (133.3)	5.98 (151.9)	9.45 (240.3)	7.87 (200.9)	14.09 (357.9)	7.25 (184.2)	---	0.63 (16)	0.63 (16)	11.76 (298.7)	6.5 (165.1)	4.0 (101.6)	100 lbs
1518*	184TC	30 (762)	5.25 (133.3)	5.98 (151.9)	9.45 (240.3)	7.87 (199.9)	14.09 (357.9)	7.25 (184.2)	---	0.63 (16)	0.63 (16)	11.76 (298.7)	6.5 (165.1)	4.0 (101.6)	132 lbs
	213-215TC	33.5 (850.9)	5.25 (133.3)	5.98 (151.9)	---	7.87 (199.9)	14.07 (357.4)	4.09 (103.9)	---	0.63 (16)	0.63 (16)	11.76 (298.7)	6.5 (165.1)	4.0 (101.6)	132 lbs
1518-2*	213-215TC	29.5 (749.3)	5.25 (133.3)	6.0 (152.4)	---	8.66 (219.9)	14.46 (367.3)	4.09 (103.9)	---	---	0.55 (13.9)	11.76 (298.7)	6.5 (165.1)	4.0 (101.6)	143 lbs
	254-256TC	33.5 (850.9)	6.25 (158.7)	6.0 (152.4)	---	9.84 (249.9)	14.97 (380.2)	4.09 (103.9)	---	---	0.55 (13.9)	12.75 (323.8)	6.5 (165.1)	4.0 (101.6)	154 lbs
	284TSC	37.35 (948.7)	7.00 (177.8)	6.0 (152.4)	---	9.84 (249.9)	14.97 (380.2)	4.09 (103.9)	0.75 (19)	---	0.55 (13.9)	13.50 (342.9)	6.5 (165.1)	4.0 (101.6)	154 lbs
2156	184TC	29 (736.6)	7.09 (180)	8.66 (219.9)	---	11.02 (279.9)	13.68 (347.5)	6.89 (175)	1.83 (46.5)	0.63 (16)	0.55 (13.9)	13.39 (340.1)	6.3 (160)	3.15 (80)	132 lbs
	213-215TC	31 (787.4)	7.09 (180)	8.66 (219.9)	11.02 (279.9)	11.02 (279.9)	14.45 (367)	3.70 (93.9)	3.54 (89.9)	0.55 (13.9)	0.38 (9.6)	13.39 (340.1)	6.3 (160)	3.15 (80)	132 lbs
2158	213-215TC	28.62 (726.9)	5.26 (133.6)	8.66 (219.9)	---	11.02 (279.9)	20.07 (509.8)	3.70 (93.9)	1.84 (46.7)	---	0.55 (13.9)	14.17 (359.9)	7.09 (180)	3.15 (80)	154 lbs
	254-256TC	32.67 (829.8)	7.09 (180)	8.66 (219.9)	---	11.02 (279.9)	19.57 (497)	3.70 (93.9)	0.84 (21.3)	---	0.55 (13.9)	14.17 (359.9)	7.09 (180)	3.15 (80)	165 lbs
	284TSC	36.5 (927.1)	7.09 (180)	8.66 (219.9)	---	11.02 (279.9)	20.27 (514.8)	3.58 (90.9)	---	---	0.55 (13.9)	14.17 (359.9)	7.09 (180)	3.15 (80)	165 lbs
2526	184TC	29 (736.6)	7.09 (180)	8.66 (219.9)	11.02 (279.9)	---	13.68 (347.5)	6.89 (175.01)	1.83 (46.5)	0.38 (9.6)	0.55 (13.9)	13.39 (340.1)	6.3 (160)	3.15 (80)	132 lbs
	213-215TC	31 (784.4)	7.09 (180)	8.66 (219.9)	11.02 (279.9)	---	14.45 (367)	3.70 (93.98)	3.54 (89.9)	0.55 (13.9)	0.38 (9.6)	13.39 (340.1)	6.3 (160.02)	3.15 (80)	132 lbs
326*	213-215TC	31 (784.4)	8.25 (209.5)	9.76 (247.9)	---	11.81 (299.9)	14.47 (367.5)	4.09 (103.9)	2.99 (75.9)	0.63 (16)	---	16.5 (419.1)	8.25 (209.5)	4.0 (101.6)	144 lbs
	254-256TC	36 (914.4)	8.25 (209.5)	9.76 (247.9)	---	11.81 (299.9)	14.97 (380.2)	4.09 (103.9)	1.99 (50.5)	0.63 (16)	---	16.5 (419.1)	8.25 (209.5)	4.0 (101.6)	144 lbs
	284TSC	37.35 (948.7)	8.25 (209.5)	9.76 (247.9)	---	11.81 (299.9)	14.97 (380.2)	4.09 (103.9)	1.25 (31.8)	0.63 (16)	---	16.5 (419.1)	8.25 (209.5)	4.0 (101.6)	144 lbs

* Meet ANSI B73.3M dimensional standards

