

Standard Product Capabilities

Pump solutions from a World Leader



MDF-L Series

Dry-run capable for handling tough chemicals

MDF-L is a family of compact close-coupled pumps incorporating patented repeatable, dry run technology. ETFE fluoropolymer wetted materials give MDF-L pumps excellent corrosion resistance to handle the most difficult chemical processes.

Modular construction simplifies pump maintenance, reduces parts cost and downtime. Casing liners, impellers, bearings and thrust surfaces are individually replaceable.

ETFE wetted parts make MDF-L pumps ideal for chemistries like HF, HCL, H₂SO₄, NaOH and others.

Installation time and maintenance time are reduced with our compact, close-coupled design.

Operating costs are reduced thanks to simple, modular construction and individually replaceable parts.

Patented pinpoint bearing system defends MDF-L pumps from dry run abuse. MDF-L pumps equipped with carbon bearings can be run dry without damage.

Think twice. Spec One

Patented pinpoint bearing

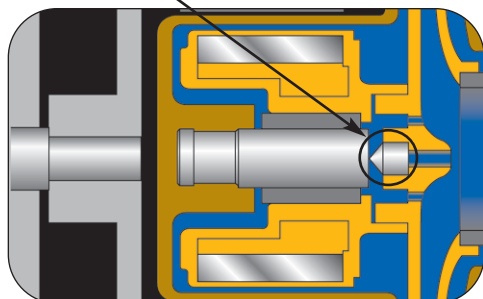

Wet End Materials

Bearing option	CF	AA
Casing liner	20% Carbon reinforced fluoroelastomer ETFE	
Containment shell bushing	High density Carbon	99.8% Alumina Ceramic
Shaft	99.8% Alumina Ceramic	
Thrust collar, inboard	99.8% Alumina Ceramic	
Impeller	20% Carbon reinforced fluoroelastomer ETFE	
O-ring	FKM/EPDM/Aflas®	
Gasket	FKM/EPDM/Aflas®	

Aflas® is a registered trademark of Asahi Glass Co., Ltd.





Specifications

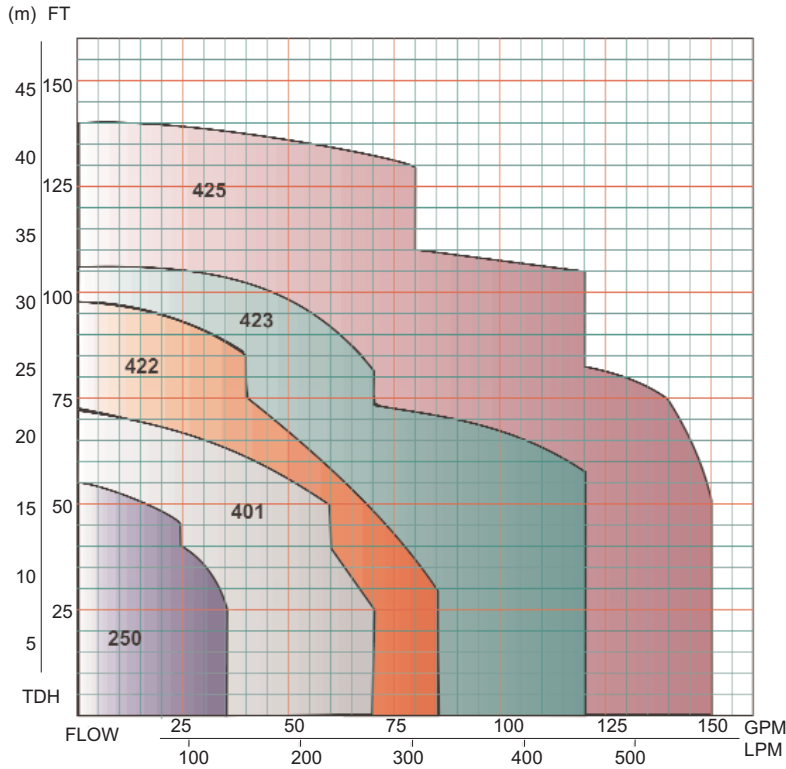

Dimensions in inches (mm) *Dimension varies with motor manufacturer.

Model	W	H	L*	Weight (less motor, lbs)
250	8.1 (205)	9.3 (237)	17.3 (439)	31
401	9.2 (233)	10.8 (275)	20.4 (519)	48
422	9.9 (251)	11.6 (295)	21.9 (557)	60
423	9.9 (251)	11.6 (295)	24.7 (627)	68
425	9.9 (251)	11.6 (295)	24.7 (627)	71

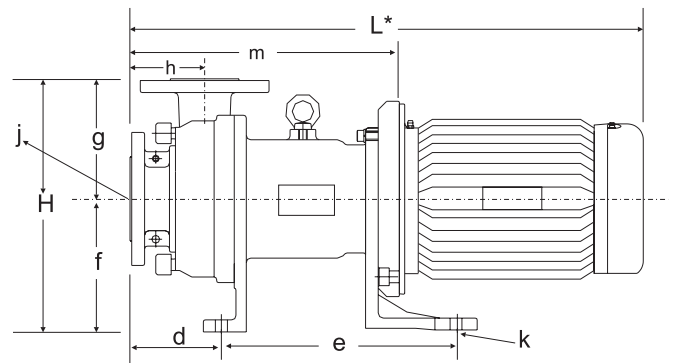

MDF-L Model	Connections Suct x Disch	Impeller Code	Max Capacity @60Hz (GPM)	Head (ft)	Min flow rate (GPM)	Motor (RPM)	Motor (HP)
250	1 x 1	G	35	55	2.5	3450	3/4
		X	45	36	2.5	3450	3/4
401	1 1/2 x 1 1/2	G	70	71	2.5	3450	1 1/2
422	2 x 1 1/2	P	60	95	5.3	3450	2
		X	85	80	5.3	3450	2
423		P	70	105	5.3	3450	3
		X	120	84	5.3	3450	3
425		P	150	135	13.2	3450	5

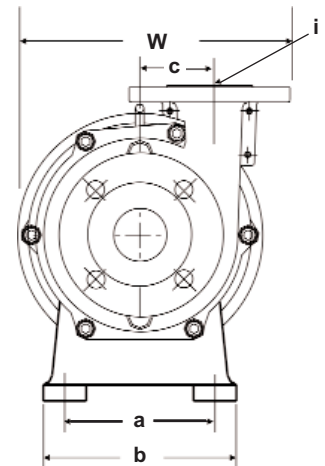

Dimensions in inches (mm)

Model	a	b	c	d	e	f	g	h	i	j	k	m
250	4.3 (110)	5.9 (150)	2.0 (51)	3.7 (95)	6.5 (165)	4.5 (115)	4.8 (122)	3.5 (88)	1.0 (25.4)	1.0 (25.4)	0.47 (12)	9.1 (231)
401	5.1 (130)	6.7 (170)	2.3 (58)	4.4 (111)	9.8 (250)	5.3 (135)	5.5 (140)	4.0 (102)	1.5 (38)	1.5 (38)	0.55 (14)	11.8 (300)
422	5.5 (140)	7.1 (180)	2.6 (66)	4.2 (107)	10.8 (275)	6.1 (155)	5.5 (140)	3.4 (87)	1.5 (38)	2.0 (51)	0.55 (14)	11.5 (293)
423	5.5 (140)	7.1 (180)	2.6 (66)	4.2 (107)	10.8 (275)	6.1 (155)	5.5 (140)	3.4 (87)	1.5 (38)	2.0 (51)	0.55 (14)	12.4 (315)
425												

IALT-00050.C Mar 2009

