

# M Series

## Chemical Process Pumps

Sealless   Corrosion Resistant   Leak Free



# M

## series

### MDM Series

#### ANSI Dimensional for ease of installation

MDM Series is an ANSI dimensional pump with flow rates to 400 GPM and TDH to 348 feet. Available in both ETFE Teflon® and virgin PFA for high purity applications. The MDM series options include an elevated temperature rating up to 302°F and solids handling up to 10%.

**Robust ceramic/SiC shafts have front & rear support, eliminating shaft deflection and allowing full-curve operation**

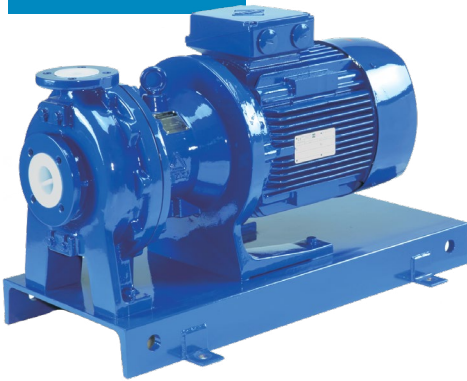

\* ANSI dimensional

Model	Connections Suction x Discharge 150# (inch)	Max. Head (ft)	Max. Capacity (GPM)	Motor HP
<b>1516*</b>	1½ x 1	117	60	2 / 3
<b>1518*</b>	1½ x 1	173	70	5 / 7.5 / 10
<b>1518-2*</b>	1½ x 1	348	120	7.5 / 10 / 15 / 20 / 25
<b>2156</b>	2 x 1½	131	150	5 / 7.5 / 10
<b>2158</b>	2 x 1½	329	160	7.5 / 10 / 15 / 20 / 25
<b>2526</b>	2½ x 2	155	250	5 / 7.5 / 10
<b>326*</b>	3 x 2	176	350	7.5 / 10 / 15 / 20 / 25
<b>3158*</b>	3 x 1.5	312	400	7.5 / 10 / 15 / 20 / 25 / 30 / 40 / 50
<b>328*</b>	3 x 2	323	400	7.5 / 10 / 15 / 20 / 25 / 30 / 40 / 50

### MXM Series

#### Cost Effective, Sub ANSI Design for Lower Flow Applications

MXM Series is a compact, cost efficient option where applications fall below ANSI dimensional pumps. The MXM is rated to 160 GPM and TDH up to 142 feet. It comes standard with corrosive resistant ETFE Teflon® internals, 150# ANSI flanges and a back pull-out design for easy maintenance.



Model	Connection Size Suction x Discharge	Min. Flow (GPM)	Max. Head (ft)	Max. Capacity (GPM)	Motor/Frame
<b>MXM-220_</b>	1" x 1"	2.5	38	55	½ - 1 HP / 56C
<b>MXM-221_</b>		2.5	63	55	
<b>MXM-441_</b>	1½" x 1½"	5.5	80	75	1 HP / 56C
<b>MXM-442_</b>		5.5	95	72	2 HP / 145 TC
<b>MXM-542_</b>	2.0" x 1½"	5.5	96	115	2 HP / 145 TC
<b>MXM-543_</b>		5.5	122	160	3 HP / 182 TC
<b>MXM-545_</b>		13.2	142	160	5 HP / 184 TC

# M Series Performance

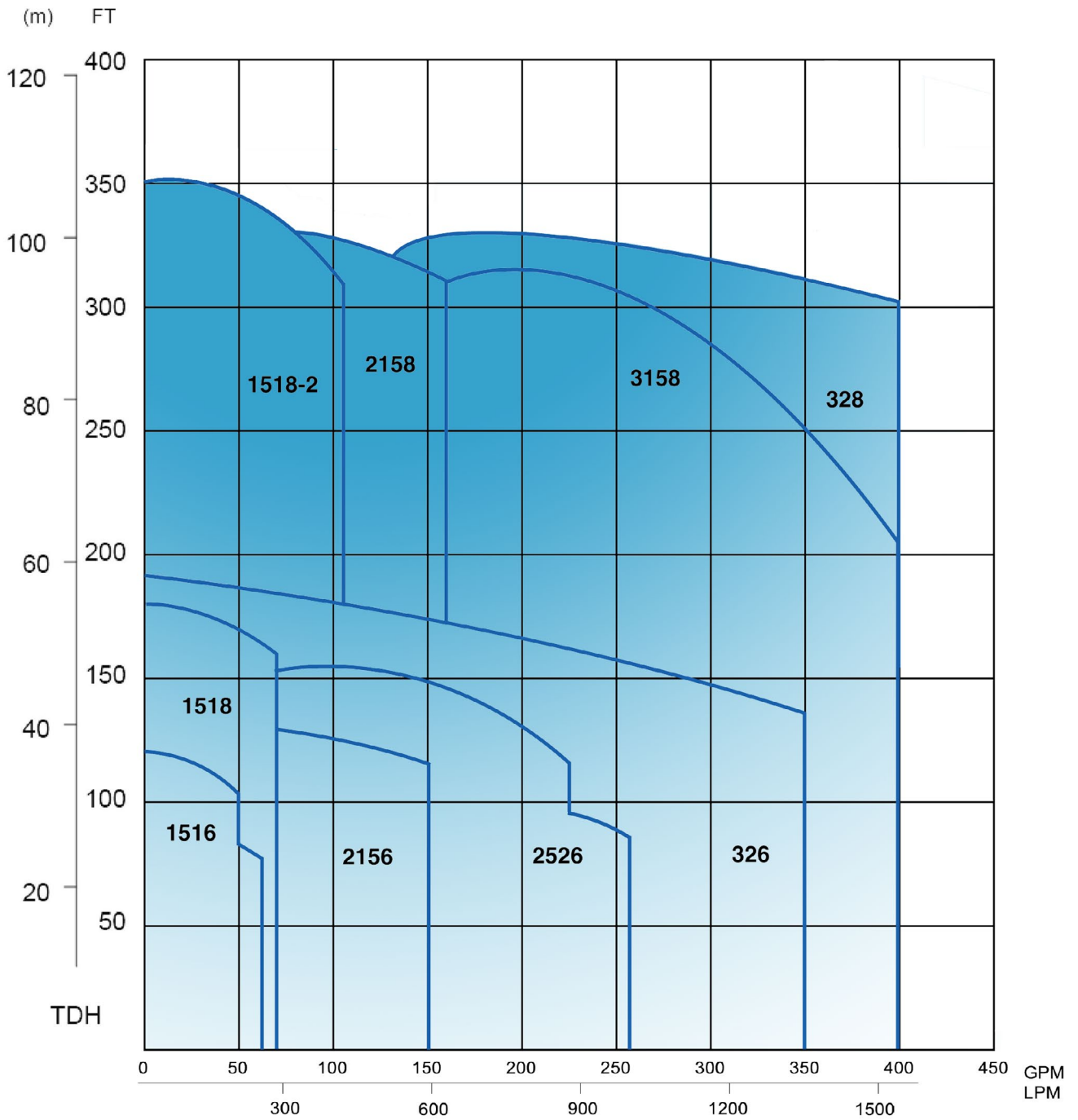

## MX-(F) Series

High efficiency volute design for improved pump efficiencies

2-piece impeller/magnet design lowers parts costs

MX-(F) Series is available in both glass-filled reinforced polypropylene and ETFE Teflon®. It is rated to 225 GPM and TDH to 126 feet. Male by male NPT connections and NEMA-C-faced motors make the MX series incredibly easy to install and operate.

MX Model	Suction x Discharge (NPT)	Max Head (ft)	Max. Flow (GPM)	Motor Output @ 60 Hz (HP)		
Polypropylene	250	1" x 1"	53	40	0.5	
	251	1" x 1"	75	40	1.0	
	400	6	1.5" x 1.5"	38	70	0.75
		7	1.5" x 1.5"	43	70	0.75
	401	6	1.5" x 1.5"	59	80	1.5
		7	1.5" x 1.5"	68	80	1.5
	402	2" x 1.5"	73	107	2	
	402H	2" x 1.5"	99	45	2	
	403	2" x 1.5"	101	130	3	
	403H	2" x 1.5"	126	70	3	
505*	2.5" x 2"	86	225	5		
Teflon®	F250	1" x 1"	48	43	0.5	
	F251	1" x 1"	69	40	1	
	F400	V	1.5" x 1.5"	43	65	0.75
		X	1.5" x 1.5"	34	65	0.75
	F401	V	1.5" x 1.5"	68	86	1.5
		X	1.5" x 1.5"	50	75	1.5
	F402	2" x 1.5"	70	120	2	
	F403	2" x 1.5"	93	130	3	

\* Flange only



## SMX-(F) Series

Self-priming

SMX-(F) Series is a self-priming compact pump that is capable of lifting up to 13 feet of fluid in under 90 seconds. Available in 10 different flow configurations, this polypropylene or ETFE Teflon® pump produces flows over 130 GPM and TDH up to 120 feet.

SMX Model	Connections Suction x Discharge	Impeller Code	Max Capacity (GPM)	Max Head (ft)	Motor (HP)
(F)220	1 x 1	Y	25	35	½
(F)221	1 x 1	X	45	60	1
(F)221	1 x 1	Y	34	35	1
(F)222	1 x 1	X	45	60	2
(F)441	1½ x 1½	Y	74	49	1
(F)442	1½ x 1½	X	90	84	2
(F)443	1½ x 1½	X	90	84	3
(F)543	2 x 1½	Z	110	96	3
(F)545	2 x 1½	Y	132	112	5
(F)545	2 x 1½	X	132	119	5





## M Series Dry-Run Capable Pumps

Iwaki America is proud to offer our M Series pumps for your toughest chemical handling applications. All Non-Metallic Series pumps feature our non-contact, dry-run capable structure. When fitted with a carbon bearing, the M Series allows for periods of repeatable dry running with no damage to the pump. This proven non-contact principle also greatly improves the ability to withstand cavitation, poor suction conditions and running against a closed discharge valve. During adverse operating conditions, the M Series high strength magnets align to open contact points in the front or rear of the pump preventing damage to internal bearing surfaces and surrounding materials.

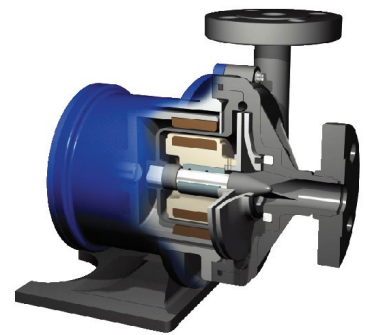
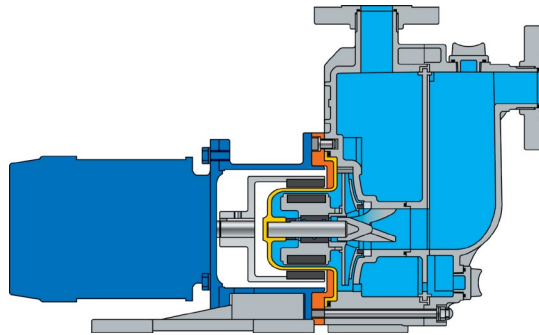
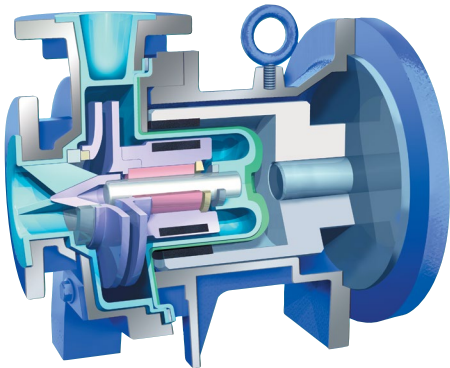

## INDUSTRY APPLICATIONS

- Battery Manufacturing • Water Treatment • Mining
- Desalination • Pulp + Paper • Chemical Transfer • Filling/Toting • Ethanol
- Semiconductor • Plating • Bio-Fuels • Sulfuric Acid • Ammonia
- Bleach • Caustic Soda • Hydrochloric Acid • Nitric Acid

# Iwaki Sanwa Metallic Sealless Pumps

With flows rates to 340 GPM and TDH over 390 ft. this series of 316 Stainless Steel pumps provides incredible performance in a small powerful package. Capable of handling temperatures from negative -112\* to 536\* F the Iwaki Sanwa line of pumps is perfect for high and low temperature applications.

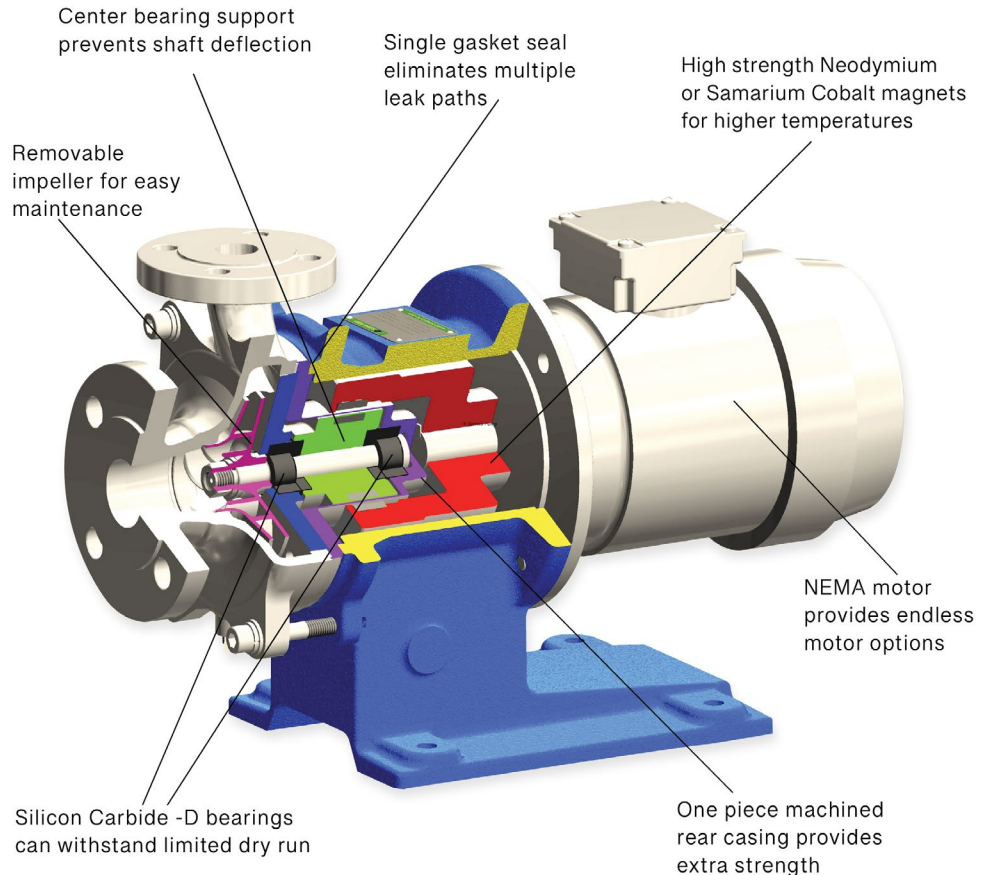

## Curves

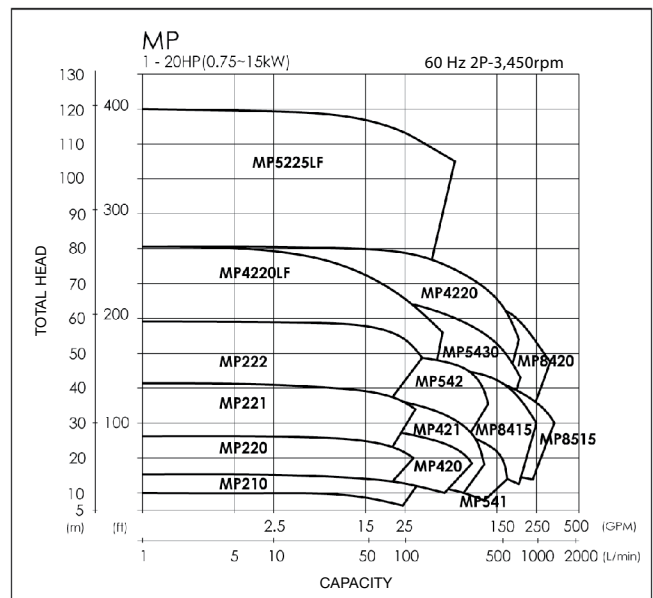
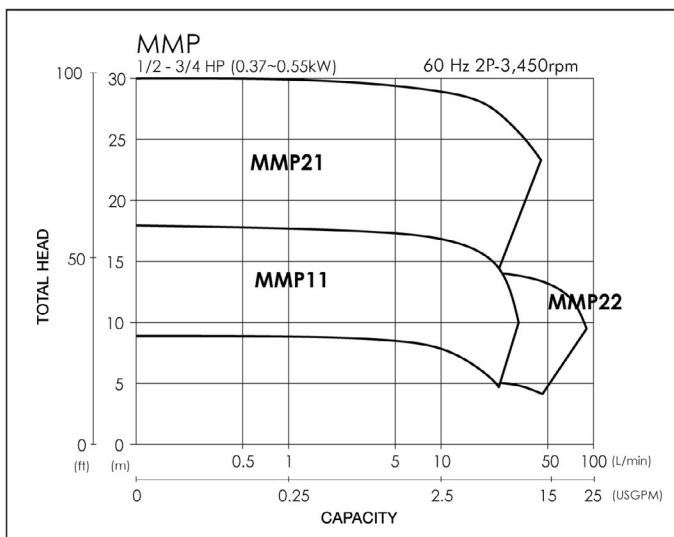

# Metering Pumps

Iwaki America offers two series of metering pumps for industrial applications. The IX series of pumps feature flow rates to 80 GPH with pressure to 250 PSI. This intuitive pump adjusts to process conditions via a pulse or analog input. Its microprocessor control also allows for timed or batched metering. The LKN series features flows to 114 GPH and pressure to 225 PSI. Multiple liquid end material choices along with motor voltage/service options make the LKN series ideal for the toughest chemical application.

## IX Series



Model	Capacity (GPH)	Max Pressure (PSI)	Connection	Material Options
<b>IX-B007</b>	2.0	250	3/8" OD Tube or 1/2" NPT	PVDF or Stainless Steel
<b>IX-B015</b>	4.0	150	3/8" OD Tube or 1/2" NPT	
<b>IX-B030</b>	7.9	87	1/2" OD Tube or 1/2" NPT	
<b>IX-B045</b>	11.9	58	1/2" OD Tube or 1/2" NPT	
<b>IX-C060</b>	15.6	145	1/2" NPT	
<b>IX-C150</b>	39.6	58	3/4" NPT	
<b>IX-D150</b>	39.6	145	3/4" NPT	
<b>IX-D300</b>	79.2	73	1" NPT	

Model	Capacity*	Max Pressure (PSI)		Stroke Speed (SPM)	Connection (NPT)
		PVC/PVDF	SS		
<b>LKN32</b>	9.5	150	225	116	1/2"
<b>LKN45</b>	15.9	150	225	58	1/2"
<b>LKN47</b>	31.8	120	120	116	1/2"***
<b>LKN55</b>	53.4	75	75	58	1"
<b>LKN57</b>	114.3	45	45	116	1"

\* Capacities listed are at Max. pressure. \*\* LKN47 with VS liquid end has 1" NPT connections



## LKN Series

## Accessories

### Power Monitor (DRN)

Iwaki DRN monitors the input power to the pump. Capable of detecting both over-load and under-load conditions, the monitor offers protection from off-design conditions such as; dry running, dead head, end of curve, cavitation and excessive bearing wear.



### Non-Metallic Baseplates

Corrosion resistant Basetek® polymer concrete non-metallic bases are available for all M-Series products. Bases use stainless steel inserts as a standard and are available with optional grout holes, and drip pan. These non-metallic bases are designed to accommodate all of our close-coupled designs and complement the rugged quality and corrosion resistance of our M-Series products.



### Variable Frequency Drive

The Baldor ACS Drives feature easy-to-use, plain language interfaces and control routines to support UL Type 1 and Type 12 applications at 230V, 460V and 600V. The ACS Drive uses a traditional inverter V/Hz control or sensorless vector control to cover a wide variety of applications. At power-up, a start-up assistant quickly and easily guides the user through the first time setup of the drive.





5 Boynton Road | Hopping Brook Park  
Holliston, MA 01746 USA | TEL: 508-429-1110 | [info@iwakiamerica.com](mailto:info@iwakiamerica.com)

**IwakiAmerica.com**

ISO 9001 registered company

P/N IALT00130.N Jun 2025