



EH Series High Viscosity Electronic Metering Pumps Instruction Manual



Five Boynton Road Hopping Brook Park Holliston, MA 01746 USA TEL 508-429-1110 FAX 508-429-7433
WEBSITE: www.IwakiAmerica.com

Notice

© 2005 IWAKI AMERICA Corporation
Five Boynton Road, Holliston, MA 01746 USA
tel (508) 429-1110 fax (508) 429-7433
All Rights Reserved
Printed in USA

Proprietary Material

The information and descriptions contained herein are the property of IWAKI AMERICA Corporation. Such information and descriptions may not be copied or reproduced by any means, or disseminated or distributed without the express prior written permission of IWAKI AMERICA Corporation.

This document is for information purposes only and is subject to change without notice.

Statement of Limited Warranty

IWAKI AMERICA Corporation warrants equipment of its manufacture and bearing its identification to be free from defects in workmanship and material for a period of two years from date of delivery from the factory or authorized distributor under normal use and service and otherwise when such equipment is used in accordance with instructions furnished by IWAKI AMERICA Corporation and for the purposes disclosed in writing at the time purchased, if any. IWAKI AMERICA Corporation's liability under this warranty shall be limited to replacement or repair, F.O.B. Holliston, MA U.S.A. of any defective equipment or part which, having been returned to IWAKI AMERICA Corporation, transportation charges prepaid, has been inspected and determined by IWAKI AMERICA Corporation to be defective.

THIS WARRANTY IS IN LIEU OF ANY OTHER WARRANTY, EITHER EXPRESS OR IMPLIED, AS TO DESCRIPTION, QUALITY, MERCHANTABILITY, FITNESS FOR ANY PARTICULAR PURPOSE OR USE, OR ANY OTHER MATTER.

*P/N 180326.E
Jun, 2007*

TABLE OF CONTENTS

Thank you for choosing an Iwaki America EH Series metering pump. This instruction manual deals with the correct installation, operation, maintenance and troubleshooting procedures for the EH-HV model metering pumps. Please read through it carefully to ensure the optimum performance, safety and service of your pump.

1.0	INTRODUCTION	1
1.1	Safety and Caution Notes	1
1.2	Principle of Operation.....	1
1.3	Model Code.....	2
1.4	Specifications	3
1.5	Dimensions	4
2.0	INSTALLATION.....	6
2.1	Unpacking	6
2.2	Location.....	6
2.3	Electrical.....	7
3.0	OPERATION	7
3.1	Priming	7
3.2	Adjustment	7
3.3	Calibration	8
3.4	External Control.....	8
3.5	STOP Function.....	18
3.6	AC Power Interruption (Y and E Control Modules)	18
4.0	MAINTENANCE	19
4.1	Diaphragm Replacement.....	19
4.2	Valve Replacement	19
5.0	EXPLODED VIEW AND PARTS LIST	20
6.0	TROUBLESHOOTING	21
7.0	SERVICE POLICY.....	21

1.0 INTRODUCTION

1.1 Safety and Caution Notes



Always wear protective clothing, eye protection and gloves before working on or near a metering pump. Follow all recommendations of the supplier of the solution being pumped. Refer to the MSDS from the solution supplier for additional precautions.

Iwaki America EH Series metering pumps should be installed where ambient temperatures do not exceed 122°F (50°C) or do not fall below 32°F (0°C), or where pump or tubing are directly exposed to sunlight.



WARNING Risk of electrical shock! This pump is supplied with a grounding conductor and grounding-type attachment plug. To reduce the risk of electrical shock, be certain that it is connected only to a properly grounded, grounding type receptacle with ratings conforming to the data on the pump data plate. Prior to performing any maintenance on a pump, disconnect the pump from the electrical power source.



Plumbing Precautions

All piping must be securely attached to the fittings prior to starting the pump (see Section 2.2). Always adhere to local plumbing codes and requirements. Be sure that the installation does not constitute a cross connection. Iwaki America is not responsible for improper installations. Prior to performing any maintenance on a pump, depressurize the discharge tubing.

If you are pumping downhill or into little or no system pressure, a back pressure/anti-syphon device must be installed to prevent over-pumping. Contact your Iwaki America distributor for additional information.



Solution Compatibility

CAUTION! This pump has been tested by Underwriters Laboratories Inc. using water only. The suitability of this pump for use with liquids other than water is the responsibility of the user. For liquids other than water, select the best-suited liquid end material combination using a chemical compatibility chart.

1.2 Principle of Operation

The EH series electronic metering pump consists of a pump unit, a drive unit, and a control unit. The drive unit is an electromagnetic solenoid. When the solenoid coil is energized by the control unit the armature shaft moves forward due to the magnetic force of the solenoid. The shaft is attached to a PTFE faced diaphragm which is part of the pump unit. The diaphragm is forced into the pump head cavity decreasing volume and increasing pressure which forces liquid in the pump head out through the discharge check valves. When the solenoid coil is de-energized, a spring returns the armature to its starting position. This action pulls the diaphragm out of the head cavity increasing volume and decreasing pressure. Atmospheric pressure then pushes liquid from the supply tank through the suction check valves to refill the pump head.

1.3 Model Code

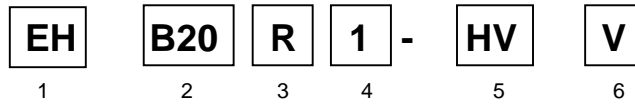

1 Pump Series

EH Electronic metering pump with external pulse control or manual speed control (adjustable to 240 strokes per minute) and manually adjustable stroke length. (Typical turndown ratio 100:1.)

2 Capacity/Pressure Rating (See Section 1.4 for detailed chart.)

3 Control Module

R For use on all EHB & EHC models, features external pulse control.
Y For use on all EHB & EHC models, features analog, pulse divide and multiply.
E For use on all EHE models, features analog, pulse divide and multiply.

4 Voltage

1 115 VAC, 50/60 Hz
2 230 VAC, 50/60 Hz

5 Liquid End HV

PVC	Head and fittings	PTFE	Diaphragm (bonded to EPDM)
CE	Valve ball	FKM	Valve seal
HC	316SS Valve spring	PTFE	Gasket
PCTFE	Valve seat		

CE	Alumina ceramic	PCTFE	Polychlorotrifluoroethylene
EPDM	Ethylene propylene diene monomer	PTFE	Polytetrafluoroethylene
FKM	Fluoroelastomer	PVC	Polyvinylchloride
HC	Hastelloy C276		

6 Options

V Standard NPT connection with back pressure/anti-siphon valve included.

BLANK No option

1.4 Specifications

Electrical	50/60 Hz, single phase		
EHB	115 VAC±10%	0.9 Amp max.	16 watt avg.
	230 VAC±10%	0.3 Amp max.	16 watt avg.
EHC	115 VAC±10%	1.4 Amp max.	24 watt avg.
	230 VAC±10%	0.5 Amp max.	24 watt avg.
EHE	115 VAC±10%	1.8 Amp max.	48 watt avg.
	230 VAC±10%	0.8 Amp max.	48 watt avg.

Operating Conditions

Ambient temperature	32°F to 122°F (0°C to 50°C)
Relative humidity	30% to 90% non-condensing
Liquid temperature	32°F to 104°F (0°C - 40°C)

Capacity/Pressure Rating

Size	Maximum Output Capacity		Output per Stroke (mL)		Maximum Pressure		Connection Size (in)
	(Gal/hr)	(mL/min)	Min.	Max.	PSI	MPa	
B20	1.0	65	0.11	0.26	50	0.35	½" NPT
C20	1.5	95	0.16	0.40	50	0.35	½"NPT
C30	2.0	126	0.21	0.52	50	0.35	½" NPT
E35	4.0	252	0.21	1.05	50	0.35	¾" NPT

Adjustment Range

Recommended stroke length adjustment range

EHB, EHC 40% to 100%

EHE 20% to 100%

Frequency adjustment range

0 to 240 strokes per minute

1.5 Dimensions

EHB20 Model shown for reference

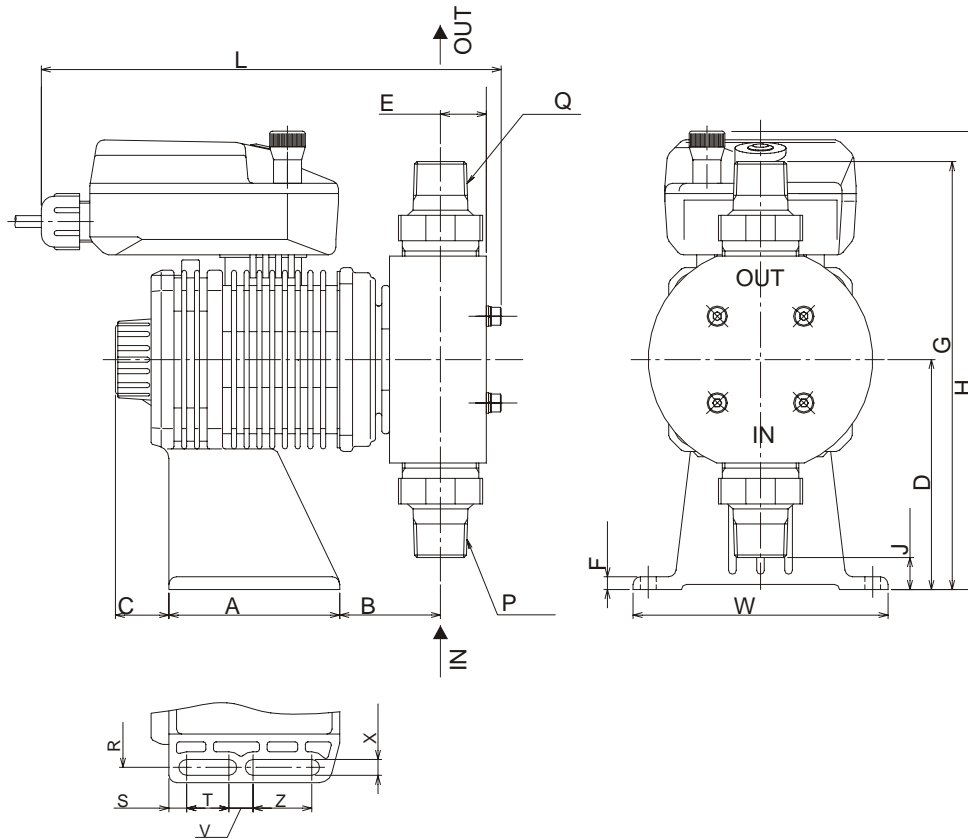

Model				A	B	C	D	E	F	G	H	J	L	P & Q	W
EHB	20	R1	-HV	2.64	1.56	0.83	3.54	0.71	0.20	6.59	6.93	0.49	7.10	½" NPT	3.94
		R2									7.47		R1		
EHC	20	R1	-HV	3.82	1.41	0.67	3.94	0.71	0.20	6.99	7.46	0.89	7.96	½" NPT	4.57
		R2									7.95		R1		
EHC	30	R1	-HV	3.82	1.41	0.67	3.94	0.71	0.20	7.32	7.46	0.55	7.96	½" NPT	4.57
		R2									7.95		R1		
		Y1													
		Y2													

All dimensions in inches

Mounting Dimensions	R	S	T	V	Z	X
EHB all variations	3.46	0.28	0.65	0.37	0.91	0.24
EHC all variations	3.94	0.28	0.67	0.39	1.81	0.24

EHE35 Model Shown for reference

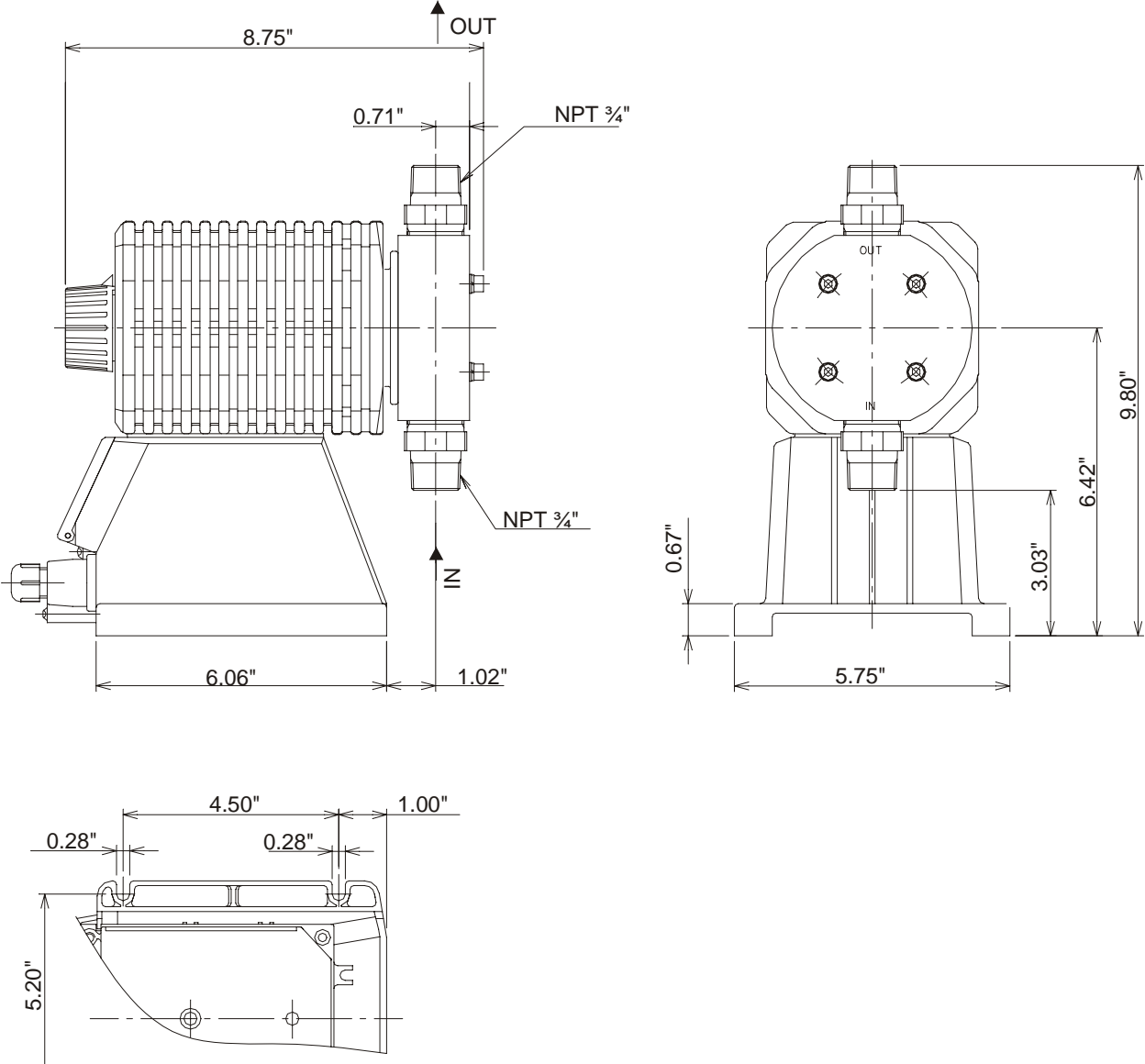

Note: The stroke length knob on EHE pumps can be forced past 100%. This will cause damage to the pump and will void the warranty.

2.0 INSTALLATION

2.1 Unpacking

Open the shipping carton and inspect contents for damage. If any items are missing or damaged contact your local distributor to arrange for replacement.



Caution: Head bolts may have loosened during storage or shipment. Be sure to check and tighten to 19 lb-in torque, if necessary.

Do not handle or move the pumps using the Control Module only. The pump should be supported by the base or drive unit during handling.

2.2 Location

Choose a location for the pump which is clean, dry, close to an electrical outlet, and allows convenient access to stroke length control, frequency control, and pipe connections. Avoid areas where ambient temperature exceeds 122°F (50°C) or falls below 32°F (0°C), or where the pump or tubing would be exposed to direct sunlight.

This pump is cord connected and not intended for permanent mounting to a building structure. However, temporary mounting to stabilize the pump during operation may be necessary as long as tools are not required for the installation or removal of the pump.

The EH-HV Series pumps require a flooded suction or pre-primed condition before operation. Flooded suction (mounting the pump below the level of liquid in the supply tank) is recommended for proper operation of high viscosity pumps. (See Figure 1) These pumps are not designed to be self-priming.

The pump is supplied with 1/2" or 3/4" (depending on model) NPT male suction and discharge connections. Mount the pump close to the supply tank and arrange the suction piping to be as short and straight as possible. Avoid piping installations where air may become trapped in the suction piping.

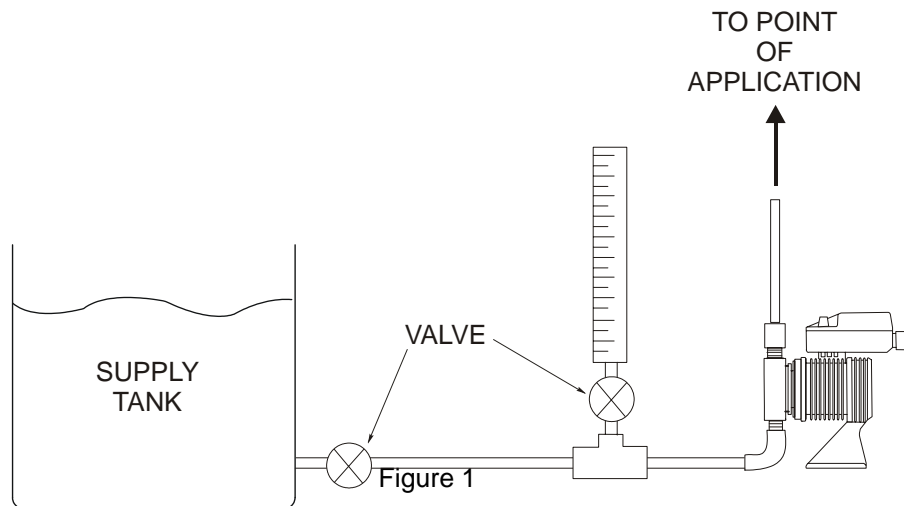

2.3 Electrical

WARNING! Risk of electrical shock! This pump is supplied with a grounding conductor and grounding-type attachment plug. To reduce the risk of electrical shock, be certain that it is connected only to a properly grounded, grounding type receptacle.

Connect the pump power cord to a **GROUND**ED outlet supplying proper voltage. Avoid branch circuits that also supply power to heavy machinery or other equipment that could generate electrical interference.

3.0 OPERATION

3.1 Priming

Install the pump as described above. With the pump turned on, set stroke length at 100% and frequency at 50%. Liquid should move through the suction piping and into the pump head.

If the pump does not begin moving liquid, remove the check valve housing on discharge & suction sides to make sure valve cartridges and gaskets are in correct positions (see section 4.2 for correct orientation).

3.2 Adjustment

A. Pumps using the 'R' Control Module

The pump will operate best with the stroke length at 100%. If less than full output is required, set the frequency to the approximate percentage of maximum desired.

Example: Model EHC20R1-HV has maximum output of 1.5 GPH.
Desired output is 1.2 GPH. $1.2 \div 1.5 = 0.8$ or 80%, so set frequency knob at 80.

For outputs less than 10% of maximum, it may also be necessary to reduce the stroke length. (Minimum recommended stroke length is 40% for EHB and EHC)

Pumps using the 'Y' and 'E' Control Modules

The pump will operate best with the stroke length at 100%. If less than full output is required, set the frequency to the desired strokes per minute using the UP and DOWN arrow keys.

Example: Model EHE35E1-HV has maximum output of 4.0 GPH.
Desired output is 3.0 GPH.
 $3.0 \div 4.0 = 0.75$ or 75%, 75% of 240 is 180.
Set spm to 180 by pushing the UP or DOWN arrow key.

For very low outputs it will be necessary to also reduce the stroke length.
(Minimum recommended stroke length is 40% for EHB and EHC, 20% for EHE)

3.3 Calibration

If exact output calibration is required, first prime and adjust the pump as above. Then connect a calibration column to the suction side of the pump. Turn the pump on for one minute and read the amount of liquid pumped from the column. Adjust the frequency up or down as necessary and check the output again. When the desired output is reached, disconnect the calibration column and reconnect the suction piping. (See Figure 2.)

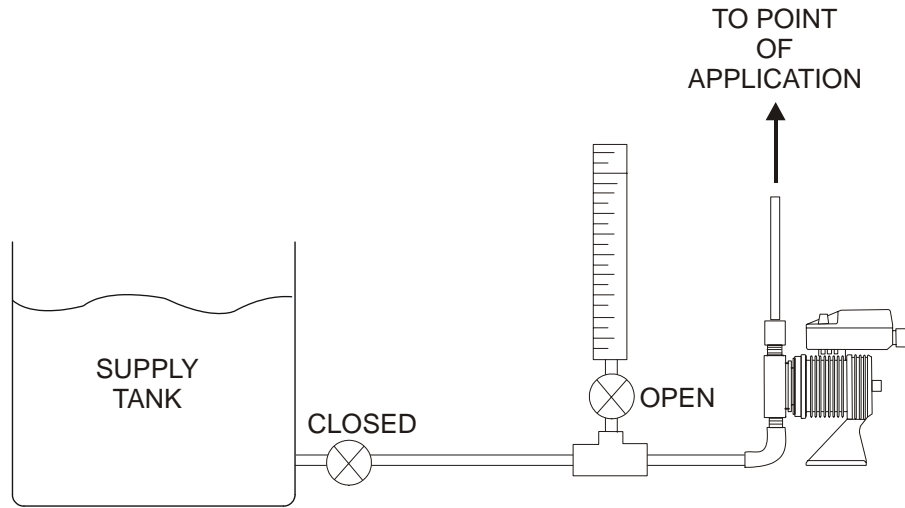

Figure 2 Calibration

3.4 External Control

A. Pumps using the 'R' Control Module

For pulse proportional external control of pump frequency, connect the control signal leads to terminals 4 (positive) and 6 (common) inside the control module. The input signal should not exceed 240 pulses per minute. The control signal can be a contact closure switch or solid state device, however, the external circuit should be capable of switching 10 VDC at 2 mA with a pulse width of 10 ms to 100 ms. (See Figure 3.)

In order for the pump to operate properly in External Mode, the frequency knob must be set fully counter clockwise so it points to the "E". (See Figure 4.)

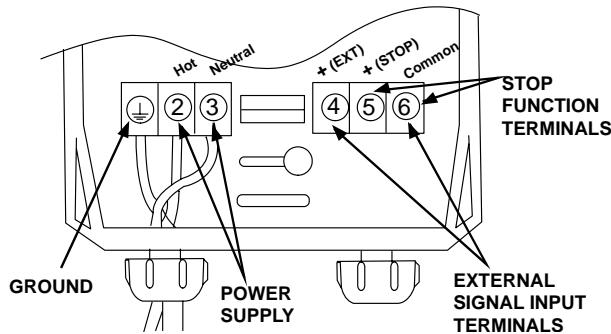

Figure 3

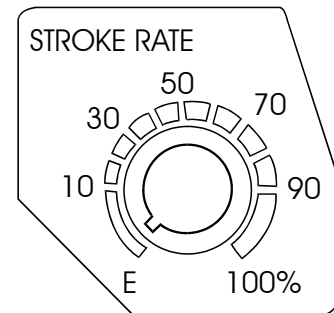

Figure 4

B. Pumps using the 'Y' Control Module

The EH-Y Series is able to operate in both digital and analog external modes. An external stop function is also available.

Display/Keypad Overview

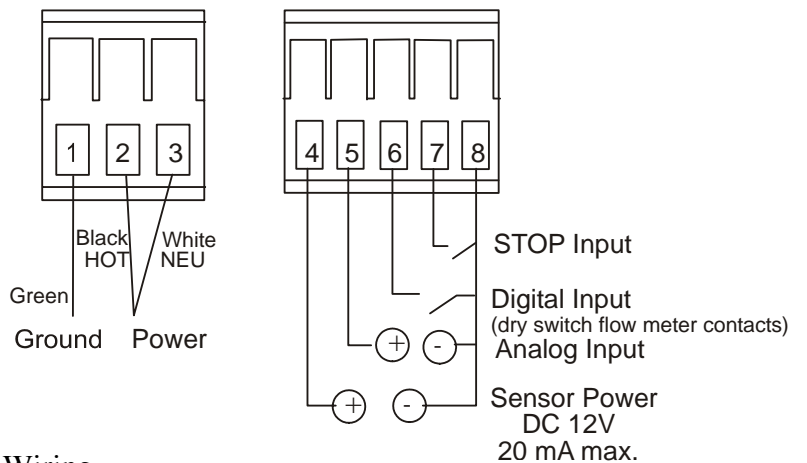
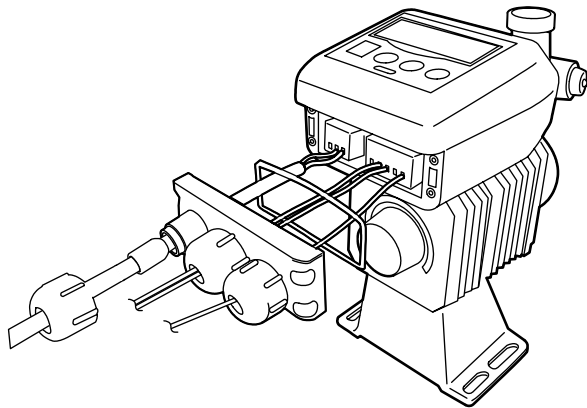
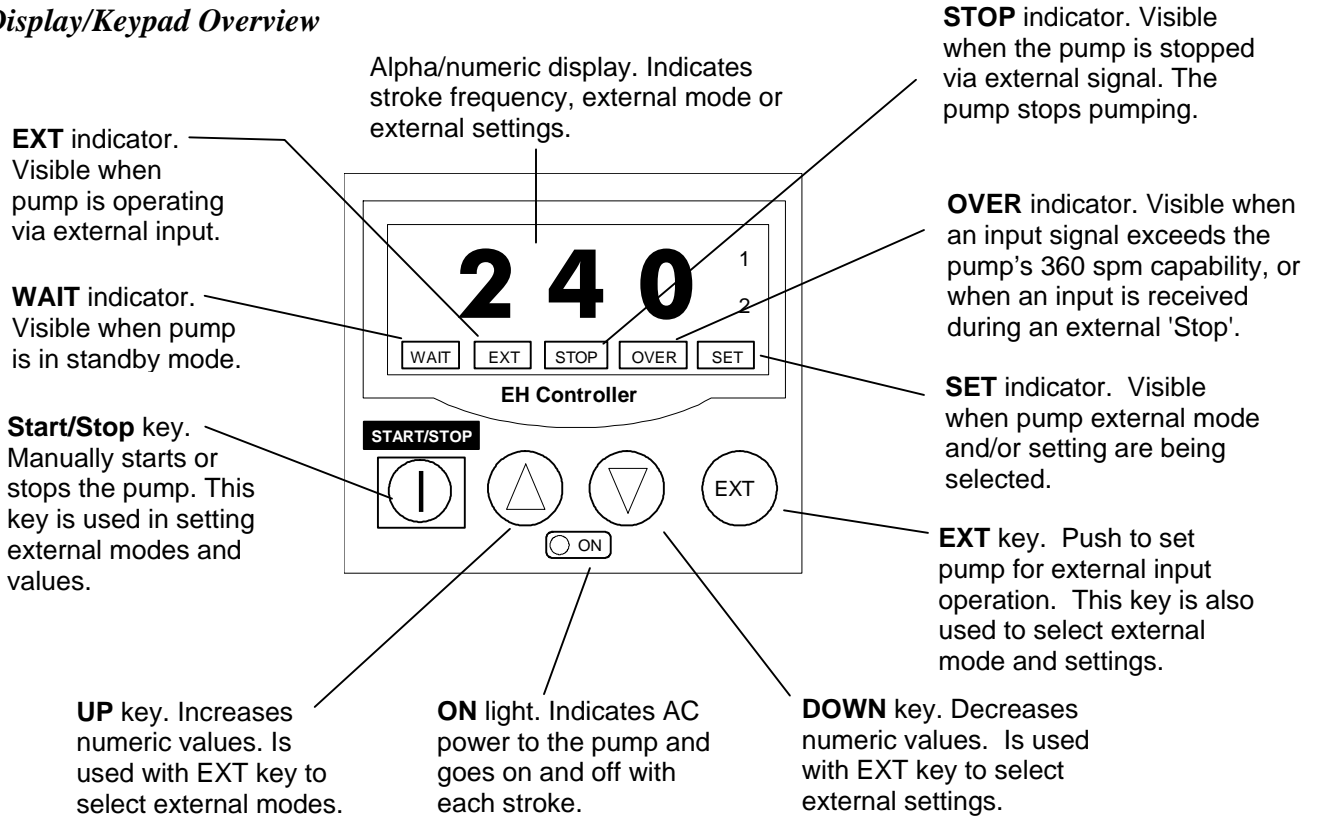
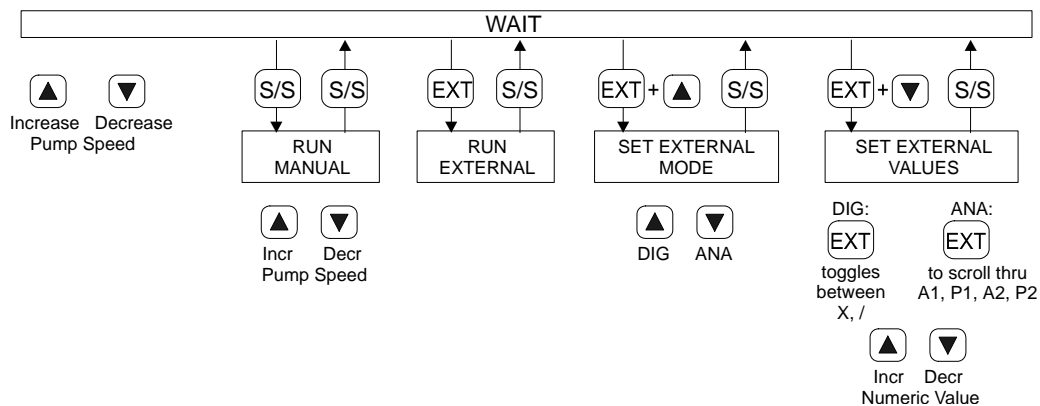

Figure 5 Input Wiring

EH-Y Quick Reference Guide

S/S Start/Stop Key
 EXT External Key

FROM:	PRESS:	TO:
WAIT MODE	S/S	Run in manual mode
	▼	Decrease frequency (1 to 360 SPM)
	▲	Increase frequency (1 to 360 SPM)
	EXT	Run in EXT ternal mode
	EXT + ▲	SET external mode
	EXT + ▼	SET external values
RUNNING IN MANUAL MODE	▲	Decrease frequency (1 to 360 SPM)
	▼	Increase frequency (1 to 360 SPM)
	S/S	Return to WAIT and stop pump operation
RUNNING IN EXT MODE	S/S	Return to WAIT and stop pump operation
SET EXTERNAL MODE	▲ OR ▼	Toggles between DIG (multiply or divide) and ANA (milliamp input)
	S/S	Accept data and return to WAIT mode
SET EXTERNAL VALUES	DIG	
	EXT	Select '/' (divide) or 'X' (multiply)
	▲	Increase value (1 to 999)
	▼	Decrease value (1 to 999)
	S/S	Accept data and return to WAIT mode
	ANA	
	EXT	Scroll through the following selections: Analog signal level (point 1) Pump speed (point 1) Analog signal level (point 2) Pump speed (point 2)
	▲	Increase value (A from 0.00 to 20.0mA) (P from 0 to 360 SPM)
	▼	Decrease value (A and P)
	S/S	Accept data and return to WAIT mode



C. Pumps using the 'E' Control Module

The EHE Series is able to operate in both digital and analog external modes. An external stop function is also available.

Display/Keypad Overview

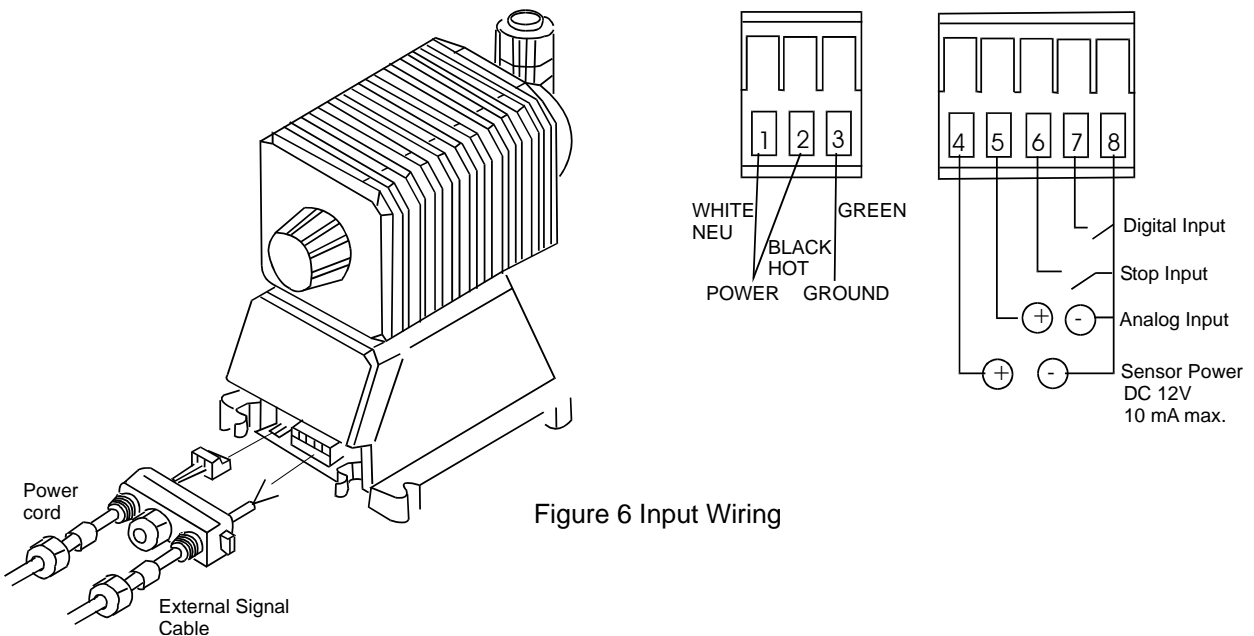
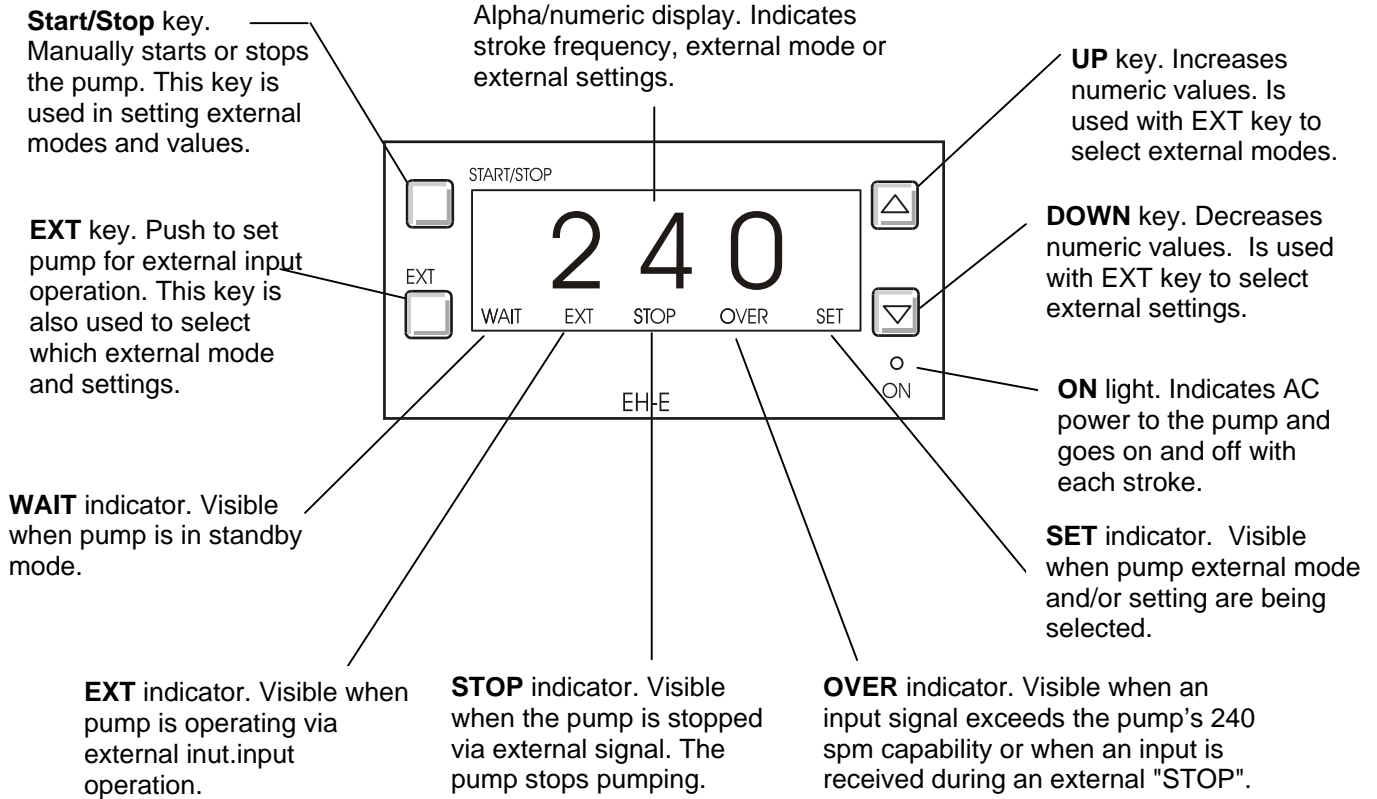

EH-E Quick Reference Guide

S/S Start/Stop Key
 EXT External Key

FROM:	PRESS:	TO:
WAIT MODE	S/S	Run in manual mode
	▼	Decrease frequency (1 to 240 SPM)
	▲	Increase frequency (1 to 240 SPM)
	EXT	Run in EXT ternal mode
	EXT + ▲	SET external mode
	EXT + ▼	SET external values
RUNNING IN MANUAL MODE	▲	Decrease frequency (1 to 240 SPM)
	▼	Increase frequency (1 to 240 SPM)
	S/S	Return to WAIT and stop pump operation
RUNNING IN EXT MODE	S/S	Return to WAIT and stop pump operation
SET EXTERNAL MODE	▲ OR ▼	Toggles between DIG (multiply or divide) and ANA (milliamp input)
	S/S	Accept data and return to WAIT mode
SET EXTERNAL VALUES	DIG	
	EXT	Select '/' (divide) or 'X' (multiply)
	▲	Increase value (1 to 999)
	▼	Decrease value (1 to 999)
	S/S	Accept data and return to WAIT mode
	ANA	
▲ OR ▼	Select 4-20, 20-0, 20-4 or 0-20	
S/S	Accept data and return to WAIT mode	

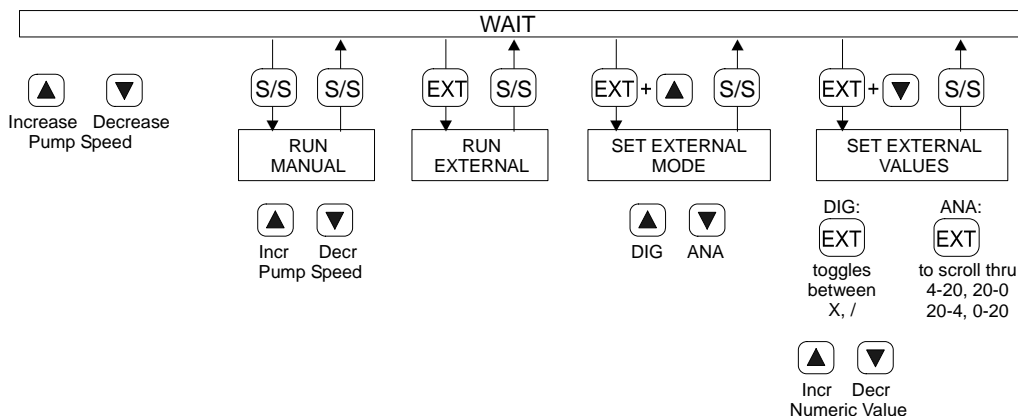

Digital Mode of Y and E Control Modules

In digital mode, the pump accepts a pulse signal from a flowmeter or other instrument. The pump can be set to divide pulses by a factor of 1 to 999; or in multiply mode, 1 input pulse can produce 1 to 999 pump strokes. Minimum pulse width is 50 mS on the Y-Control Module and 10 mS on the E-Control Module.

Connecting a digital input device

Disconnect AC power to the pump. Remove the four screws from the terminal block cover and remove the cover. Remove the cord nut and bushing from the terminal block cover. Remove the terminal block from the connector. Slide the nut and bushing over the external control cable and insert the cable through the terminal block cover. Strip 1/4" insulation from conductors and connect as shown below.

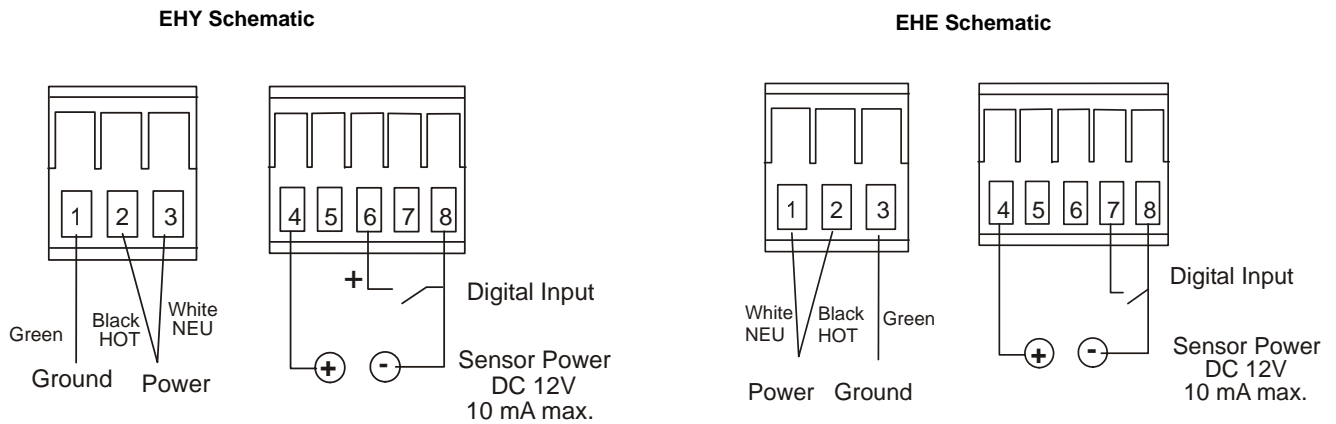

Sensor Power

The control circuit of the Y Module has the ability to provide 12 VDC at up to 10 mA and the E Module has the ability to provide 12 VDC at up to 10 mA to power a Hall effect sensor or similar device.

Connect the sensor power leads to terminal 4 (positive) and terminal 8 (negative) of the terminal block.

Settings

Start with pump in the **WAIT** state. If it is not currently in wait, press **START/STOP** once.

Press **▲** and **EXT** simultaneously.

The **SET** indicator is highlighted and **DIG** (digital) or **ANA** (analog) will be displayed.

1. Set it to digital mode

If **DIG** is displayed, press **START/STOP** to accept that mode.

You will be returned to the **WAIT** state.

If **ANA** is displayed, press the **▲** button to change to **DIG** and then press **START/STOP** to enter that choice.

You will be returned to the **WAIT** state.

2. Set multiply or divide

To set values for digital operation, press **EXT** and **▼** simultaneously. The display will show / or X and a number. Now pressing the **EXT** button will alternate between X (multiply) and / (divide).

3. Set the value

▲ or **▼** will increase or decrease the multiplier or divider. Pressing a button once will change the value by one. Holding a button down will continuously increment or decrement the value, slowly at first, then rapidly. Press **START/STOP** to accept values and return to **WAIT**.

Press **EXT** to operate the pump in external mode. The pump will now respond to the incoming pulse signal. The stroke length can be adjusted manually to set the volume pumped per stroke.

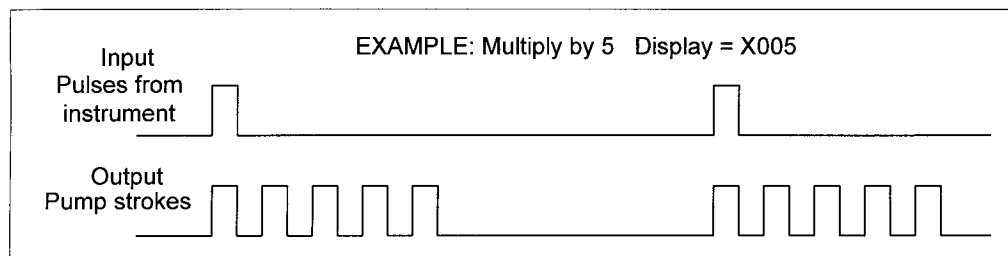

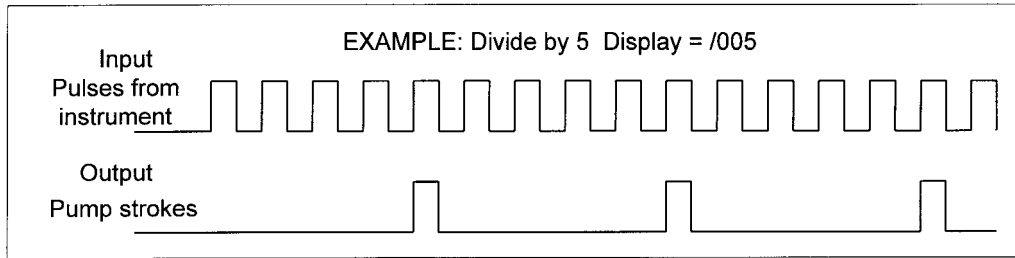

Analog Mode of Y and E Control Modules

In analog mode the pump will accept a milliamp signal and produce a pump speed proportional to the signal level received. The input resistance is 250 Ω . The pump's response can be fine-tuned by variable set points to meet system requirements.



Caution: Open loop signal voltage must not exceed 25 VDC. If the signal voltage is greater than 25 VDC, power down the signal source prior to connection and any open loop condition.

Connecting an analog signal device

Disconnect AC power to the pump. Remove the four screws from the terminal block cover and remove the cover. Remove the cord nut and bushing from the terminal block cover. Remove the terminal block from the connector. Slide the nut and bushing over the external control cable and insert the cable through the terminal block cover. Strip 1/4" insulation from conductors and connect the positive side to terminal 5 and the negative side to terminal 8. (See schematics below.)

EHY Schematic

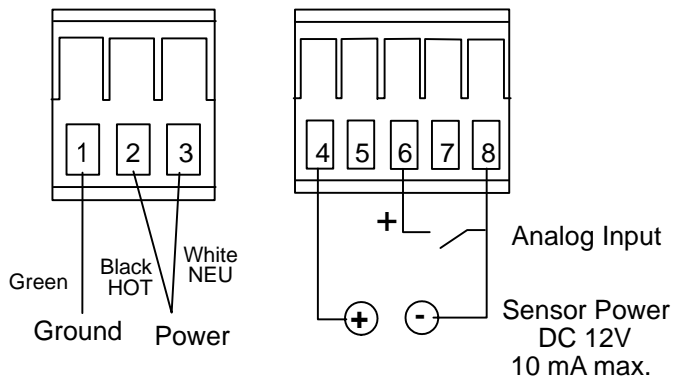

EHE Schematic

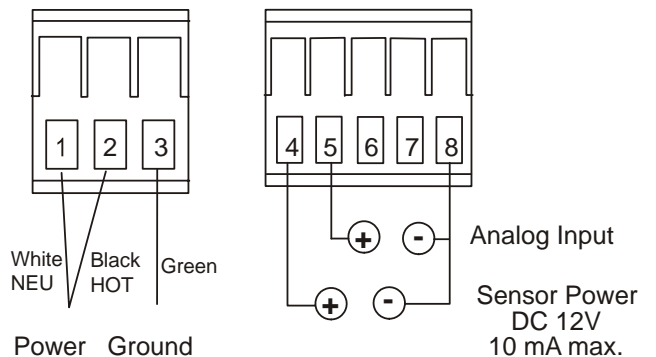

Settings

Start with pump in the **WAIT** state. If it is not currently in wait, press **START/STOP** once.

1. Set analog mode

Press **▲** and **EXT** simultaneously.

The **SET** indicator is highlighted and DIG (digital) or ANA (analog) will be displayed.

If ANA is displayed, press **START/STOP** to accept that mode. You will be returned to the **WAIT** state.

If DIG is displayed, press the **▼** button to change to ANA and then press **START/STOP** to enter that choice. You will be returned to the **WAIT** state.

2. Set values

For Y Control Module

To set values for analog operation, press **EXT** and **▼** simultaneously. The display will show A04.0 (or some value between 00.0 and 20.0 mA) with the point 1 indicator highlighted. Press **▲** or **▼** to adjust the value to the desired analog signal level for point 1.

Press **EXT** to display the pump speed for point 1. The display will show P0 (or some value between 0 and 360 spm) with the point 1 indicator highlighted. Press **▲** or **▼** to adjust the value to the desired pump speed for point 1.

Press **EXT** again to display the analog signal level for point 2, which can be adjusted as for point 1. Pressing **EXT** a third time will display the pump speed for point 2m which can be adjusted as for point 1.

Continued pressing of **EXT** key will scroll through the above four parameters for review or adjustment. When settings are as desired, press **START/STOP** to accept the new values and return to **WAIT**.

Press **EXT** to operate the pump in external mode. The pump speed will now be determined by the level of the milliamp signal as shown in the graph. The stroke length can be adjusted manually to set the volume pumped per stroke.

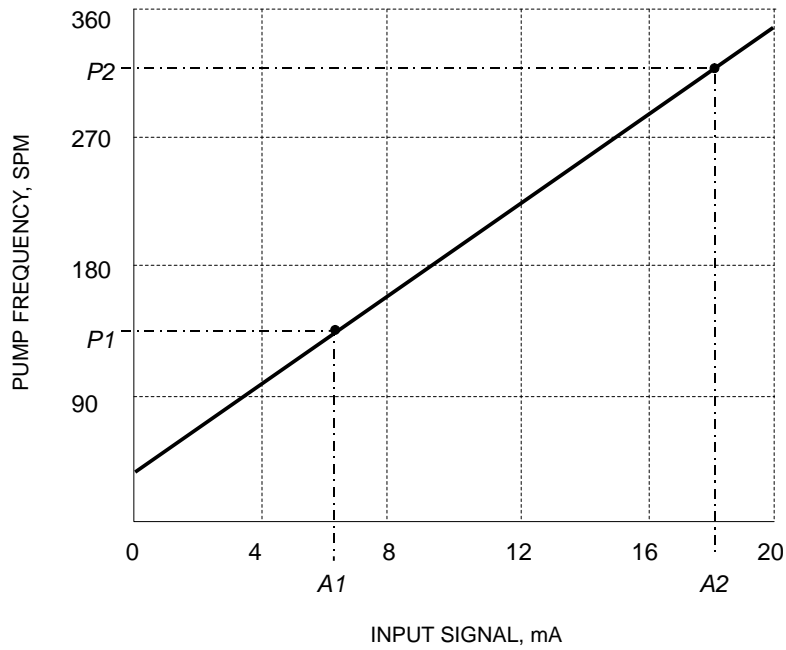

For E Control Module

To set values for analog operation, press **EXT** and **▼** simultaneously. The display will show 4—20, 20—0, 20—4 or 0—20. Press **▲** or **▼** to change the selection to the desired signal range and response. Press **START/STOP** to accept the value and return to **WAIT**.

Press **EXT** to operate the pump in external mode. The pump speed will now be determined by the level of the milliamp signal as shown in the graph. The stroke length can be adjusted manually to set the volume pumped per stroke.

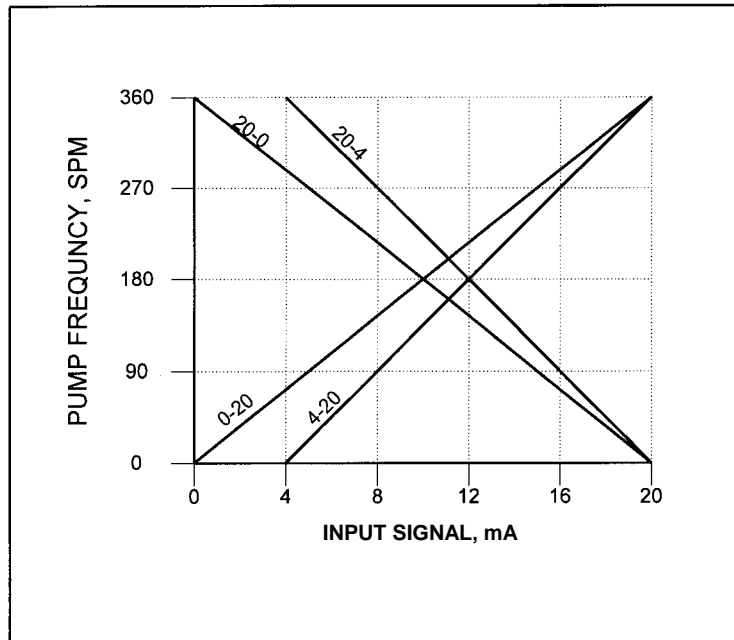

3.5 STOP Function

Additionally, the pump can be controlled in start-stop mode. In this mode, AC power is applied continuously to the pump and pump operation is stopped by completing the circuit between the positive ‘stop’ and common terminals inside the control module:

R Control Module: Terminal 5 (positive) and Terminal 6 (common)

E Control Module: Terminal 6 (positive) and Terminal 8 (common)

Y Control Module: Terminal 7 (positive) and Terminal 8 (common)

A switch or solid state device capable of switching 10 VDC at 2 mA for the R-Module and 5VDC at 2 mA for the Y and E Modules should be used. Switch closed = pump stopped, switch open = pump running at the speed determined by the frequency knob setting. This feature eliminates the need for a high voltage, high current AC relay to start and stop the pump. (See Figures 3, 5, and 6)

If using the Y or E Control Modules and the pump is operating in external digital mode, any pulses received while the pump is stopped will be saved (up to a maximum of 255). When pump operation resumes, saved pulses will allow the pump to “catch up” by producing the correct number of pump strokes that should have occurred while it was stopped.

3.6 AC Power Interruption (Y and E Control Modules)

If AC power is interrupted, the pump will power up as shown below:

State preceding power OFF	State following power ON
WAIT	WAIT
Run Manual	Run Manual
Run External	Run External
Set External mode	WAIT
Set External values	WAIT

4.0 MAINTENANCE

Caution: Before working on the pump, disconnect the power cord, depressurize the discharge tubing and drain or flush any residual liquid from the pump head and valves. Always wear protective gear when working around chemicals.

4.1 Diaphragm Replacement

Disconnect AC power to the pump and disconnect the suction tubing, discharge tubing, and air vent tubing. Remove the four head bolts with a 4mm or 5mm hex wrench. Turn the stroke length knob fully counter-clockwise. Unscrew the diaphragm and remove its retainer (small disk behind the diaphragm). **CAUTION:** *There may be small brass spacers between the retainer and the armature shaft. These spacers need to be reused when replacing the diaphragm.* Install the new retainer and diaphragm on the shaft. Turn the diaphragm clockwise until it bottoms on the shaft. Replace the pump head and tighten the head bolts to a torque of 19 lb-in (2.16 N-m).

4.2 Valve Replacement

Remove the suction and discharge tubing making sure discharge side has been depressurized. Remove the suction fitting, valve cartridge, o-ring and gaskets. Install the new o-ring, gaskets and valve cartridge. Be sure the valve seat is down. Refer to Figure below. Tighten the suction fitting. Similarly remove and replace the discharge valve cartridge, o-ring and gaskets. **CAUTION:** *There are many small parts in the liquid end. These parts must be installed correctly for proper operation of the pump.*

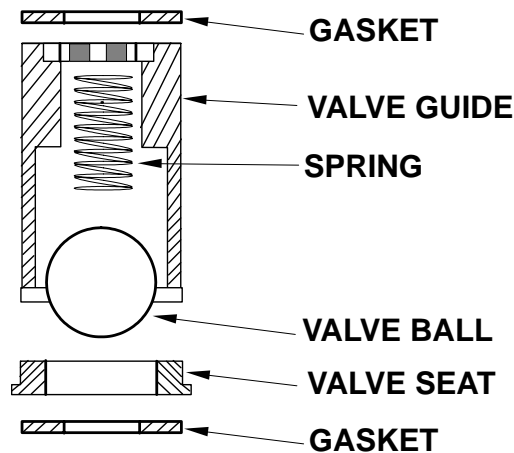

Valve Cartridge Orientation

5.0 EXPLODED VIEW AND PARTS LIST

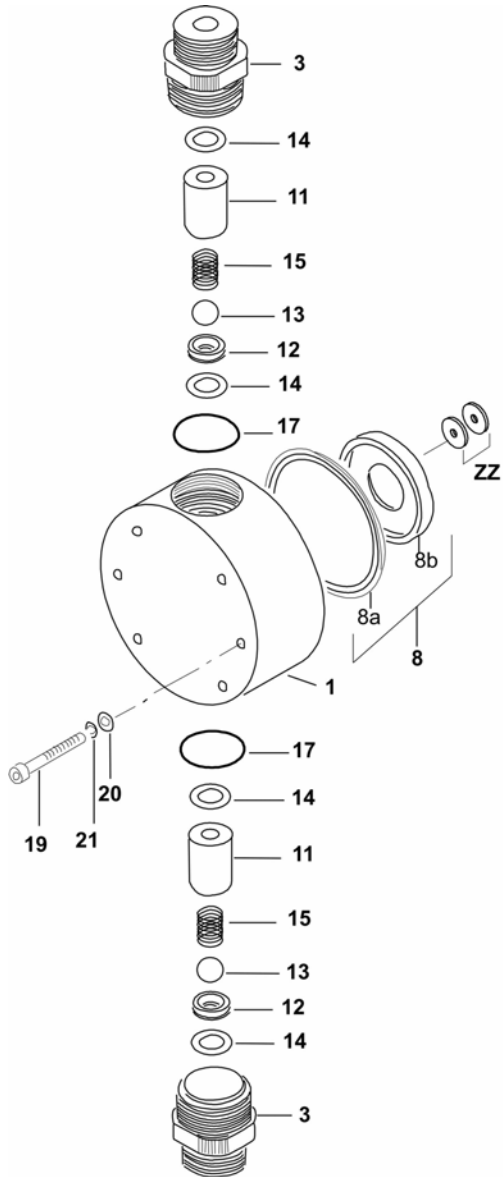

Item	Part No	Description	Qty	Size	
1	EH1241	Head, HV, PVC	1	20	
	EH1242	Head, HV, PVC	1	30	
	EH1243	Head, HV, PVC	1	35	
3	EH1244	Housing, Valve, 1/2" NPT, PVC	2	20, 30	
	E00036	Housing, Valve, 3/4" NPT, PVC	2	35	
*	8	E90061	Diaphragm and Retainer	1	20
	E90062	Diaphragm and Retainer	1	30	
	E90085	Diaphragm and Retainer	1	35	
	8a	EH0066	Diaphragm, PTFE/EPDM	1	20
	EH0086	Diaphragm, PTFE/EPDM	1	30	
	EH0636	Diaphragm, PTFE/EPDM	1	35	
8b	EH0067	Retainer, Diaphragm	1	20	
	EH0087	Retainer, Diaphragm	1	30	
	EH0637	Retainer, Diaphragm	1	35	
*	11	EH1246	Guide, Valve, .625, PVC	2	20, 30, 35
*	12	EH1247	Seat, Valve, 0.500, PCTFE	2	20, 30, 35
*	13	EH0646	Ball, Valve, 0.500, CE	2	20, 30, 35
*	14	EH0936	Gasket, Valve, 0.500, PTFE	4	20, 30, 35
*	15	EH1291	Spring, Valve, HC	2	20, 30, 35
*	17	EH0650	O-Ring, 24 X 2.62, FKM	2	20, 30, 35
19	EH1248	Bolt, M4 X 50 SHC, SS304	4	20, 30	
	EH1007	Bolt, M5 X 55 SHC, SS304	4	35	
20	EH0055	Washer, M4 Flat	4	20, 30	
	EH1253	Washer, M5 Flat	4	35	
21	EH0038	Washer, M4 Lock	4	20, 30	
	EH0628	Washer, M5 Lock	4	35	
ZZ	-----				

* Included in spare parts kit

6.0 TROUBLESHOOTING

Caution: Before working on the pump, disconnect the power cord, depressurize the discharge tubing and drain or flush any residual liquid from the pump head and valves.

<u>Problem</u>	<u>Possible Cause</u>	<u>Corrective Action</u>
<i>Pump does not start</i>	<ul style="list-style-type: none"> Faulty wiring Improper voltage Electronic control unit is damaged 	<ul style="list-style-type: none"> Correct wiring Connect to proper voltage source Replace control unit
<i>Pump does not prime</i>	<ul style="list-style-type: none"> Pump stroke length is too short Air in suction piping Valve gasket is not installed Valve set assembly direction is wrong. Pump is air locked Suction or discharge valve is clogged with foreign matter 	<ul style="list-style-type: none"> Operate pump with stroke length set at 100% until primed. Then set stroke length as needed to obtain desired output. Reroute suction piping to eliminate air trap Install valve gasket Reassemble valve set Vent air Disassemble, inspect, clean
<i>Output fluctuates</i>	<ul style="list-style-type: none"> Suction or discharge valve is clogged with foreign matter Air is trapped in pump Overfeeding Diaphragm is damaged 	<ul style="list-style-type: none"> Disassemble, inspect, clean Vent air Install injection valve or back pressure valve Replace diaphragm
<i>Liquid leaks</i>	<ul style="list-style-type: none"> Fitting is loose Pump head is loose Diaphragm is damaged O-ring or valve gasket missing 	<ul style="list-style-type: none"> Tighten Tighten pump head bolts Torque: 19 lb-in (2.16 N-m) Replace diaphragm Install o-ring or valve gasket

7.0 SERVICE POLICY

The EHB, EHC and EHE Series electronic metering pumps have a 2-year warranty.

Contact your Iwaki America distributor for service.